

CR, CRI, CRN

Vertical multi-stage centrifugal pumps
60 Hz



be
think
innovate

GRUNDFOS 

1. Product introduction	4
Performance range	5
Applications	7
Product range	8
Pump	10
Motor	10
Terminal box positions	11
Ambient temperature	11
Viscosity	11
2. Construction	12
CR 1s, 1, 3, 5, 10, 15 and 20	12
CRI 1s, 1, 3, 5, 10, 15 and 20	13
CR 32, 45 and 64	15
CRN 32, 45 and 64	16
CR 95, 125, 155	17
CRN 95, 125, 155	18
Type key	19
3. Operating and inlet pressures	20
Maximum operating pressure and liquid temperature	20
Operating range of the shaft seal	21
Maximum inlet pressure	22
4. Selection and sizing	23
Selection of pumps	23
How to read the curve charts	26
Guidelines to performance curves	27
5. Performance curves and technical data	28
CR 1s	28
CRI, CRN 1s	30
CR 1	32
CRI, CRN 1	34
CR 3	36
CRI, CRN 3	38
CR 5	40
CRI, CRN 5	42
CR 10	44
CRI, CRN 10	46
CR 15	48
CRI, CRN 15	50
CR 20	52
CRI, CRN 20	54
CR 32	56
CRN 32	58
CR 45	60
CRN 45	62
CR 64	64
CRN 64	66
CR 95	68
CRN 95	70
CR 125	72
CRN 125	74
CR 155	76
CRN 155	78
6. Motor data	80
Standard motors for CR, CRI, CRN, 60 Hz	80
7. List of pumped liquids	81
8. Accessories	83
Pipe connection	83
LiqTec	91

Sensors	92
9. Variants	93
10. Grundfos Product Center	94

1. Product introduction

This data booklet deals with Grundfos CR, CRI and CRN pumps.



Fig. 1 CR, CRI and CRN 1s-64

GR5381



Fig. 2 CR, CRI, CRN 95-155

TM06 9062 1617

CR, CRI and CRN pumps are vertical multistage, centrifugal pumps. The in-line design of the pumps enables installation in a horizontal one-pipe system where the inlet and outlet ports are in the same horizontal level and have the same pipe dimensions. This design provides a more compact pump design. CR pumps are available in various sizes and various numbers of stages to deliver the flow and pressure required.

CR pumps are designed for a variety of applications ranging from the pumping of potable water to the pumping of chemicals. The pumps are therefore suitable for a wide diversity of pumping systems where the performance and material of the pump meet specific demands.

A CR pump consists of two main components: the motor and the pump unit.

The motor is a Grundfos or Siemens motor designed to EN standards.

The pump unit consists of optimised hydraulics, various types of connections, a sleeve, a pump head and various other parts. See section 2. [Construction](#).

CR pumps are available in various material versions according to the pumped liquid.

Applications

CR, CRI and CRN pumps are designed to cover a wide variety of applications such as:

- water supply
- cooling
- heating
- pressure boosting
- water treatment
- liquid transfer of cold or hot clean liquids.

Pumped liquids

CR, CRI CRN pumps are suitable for pumping liquids which are thin, clean, non-flammable, noncombustible or non-explosive liquids, not containing solid particles or fibres.

When pumping liquids with a density and/or viscosity higher than that of water, use motors with correspondingly higher outputs, if required.

Whether a pump is suitable for a particular liquid depends on a number of factors of which the most important are chloride content, pH value, temperature, content of chemicals and oils. Please consult Grundfos for information about which pump types are suitable for a specific liquid.

See also [7. List of pumped liquids](#).

CR and CRI

CR and CRI pumps are suitable for non-corrosive liquids.

Use CR or CRI pumps for liquid transfer, circulation and pressure boosting of cold or hot clean water.

CRN

CRN pumps are suitable for industrial liquids.

Use CRN pumps in systems where all parts in contact with the liquid must be made of high-grade stainless steel.

CRT

For saline or chloride-containing liquids such as sea water or for oxidising agents such as hypochlorites, we offer CRT pumps made of titanium.

See the separate data booklet on CRT, CRTE available on Grundfos Product Center (<http://product-selection.grundfos.com/>).

Performance range

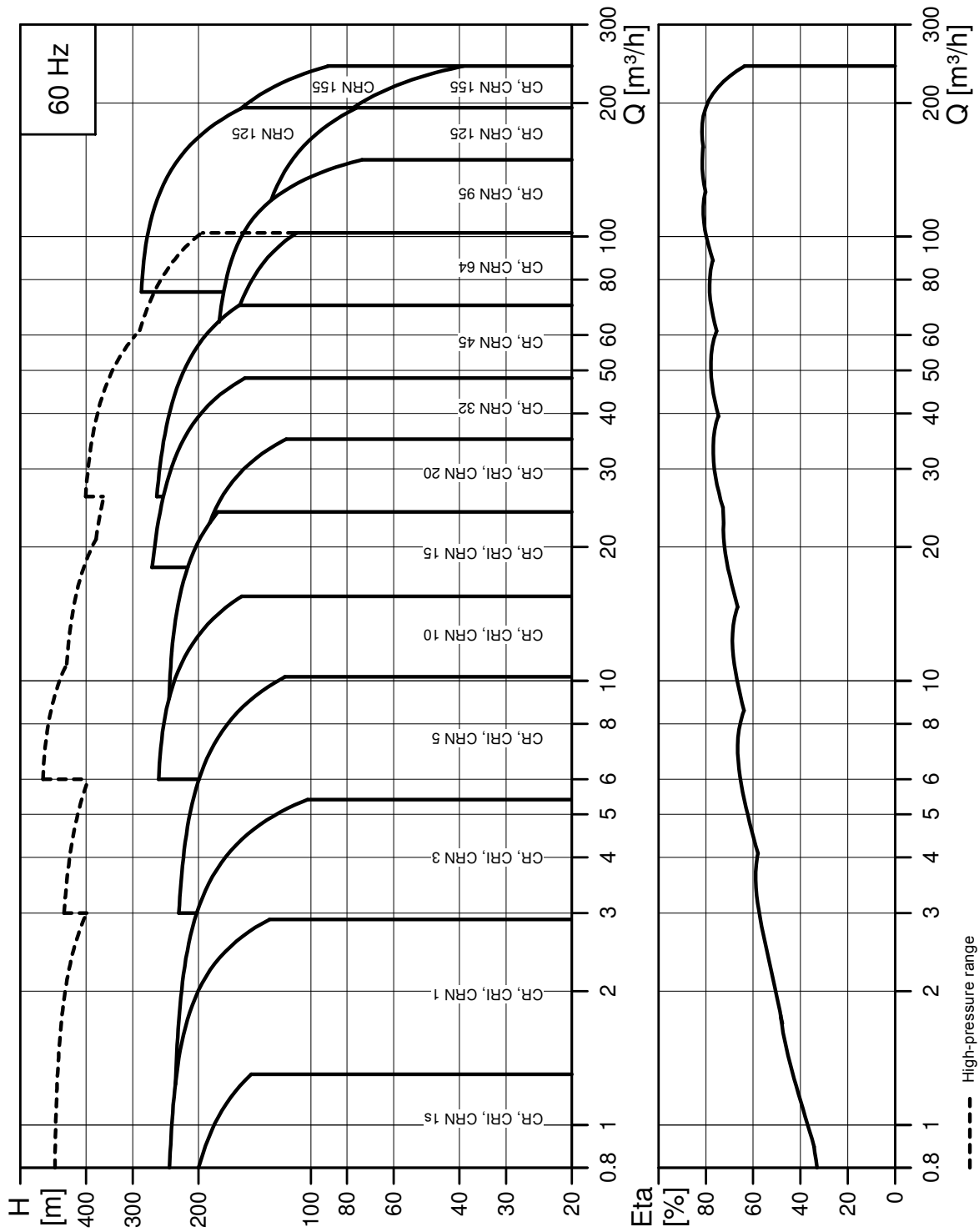

Fig. 3 Performance range, CR, CRI and CRN

TM02 1530 1318

EuP compliant

The CR, CRI, CRN pumps are energy-optimised and comply with the EuP Directive (Commission Regulation (EC) No 547/2012) which has been effective since 1 January 2013. As from this date, all pumps will be classified and graduated in a new energy minimum efficiency index (MEI).

Minimum efficiency index

Minimum efficiency index (MEI) means the dimensionless scale unit for hydraulic pump efficiency at best efficiency point (BEP), part load (PL) and overload (OL). The Commission Regulation (EU) sets efficiency requirements to $MEI \geq 0.10$ as from 1 January 2013 and $MEI \geq 0.40$ as from 1 January 2015. An indicative benchmark for best-performing water pump available on the market as from 1 January 2013 is determined in the Regulation.

- The benchmark for most efficient water pumps is $MEI \geq 0.70$.
- The efficiency of a pump with a trimmed impeller is usually lower than that of a pump with the full impeller diameter. The trimming of the impeller will adapt the pump to a fixed duty point, leading to reduced energy consumption. The minimum efficiency index (MEI) is based on the full impeller diameter.
- The operation of this water pump with variable duty points may be more efficient and economic when controlled, for example, by the use of a variable-speed drive that matches the pump duty to the system.
- Information on benchmark efficiency is available at <http://europump.eu/efficiencycharts>.

Minimum efficiency index (MEI)

Pump type	MEI
CR 1s-3	0.54
CR 1-3	> 0.70
CR 3-3	> 0.70
CR 5-3	0.57
CR 10-3	> 0.70
CR 15-3	> 0.70
CR 20-3	> 0.70
CR 32-3	> 0.70
CR 45-3	> 0.70
CR 64-3	> 0.70
CR 95-3	> 0.70
CR 125-3	> 0.70
CR 155-3	> 0.70

Applications

Application	CR, CRI	CRN
Water supply		
Filtration and transfer at waterworks	●	○
Distribution from waterworks	●	○
Pressure boosting in mains	●	○
Pressure boosting in high-rise buildings, hotels, etc.	●	○
Pressure boosting for industrial water supply	●	○
Industry		
Pressure boosting		
Process-water systems	●	●
Washing and cleaning systems	●	●
Vehicle-washing tunnels	●	○
Firefighting systems	●	-
Liquid transfer		
Cooling and air-conditioning systems (refrigerants)	●	○
Boiler feed and condensate systems	●	○
Machine tools (cooling lubricants)	●	●
Aquafarming*	●	○
Special transfer duties		
Oils and alcohols	●	●
Acids and alkalis*	-	●
Glycol and coolants	●	-
Water treatment		
Ultra-filtration systems	-	●
Reverse osmosis systems*	-	●
Softening, ionising, demineralising systems	-	●
Distillation systems	-	●
Separators	●	●
Swimming baths*	-	●
Irrigation		
Field irrigation (flooding)	●	○
Sprinkler irrigation	●	○
Drip-feed irrigation	●	○

● Recommended version.

○ Alternative version.

* CRT version available.

For further information about CRT pumps, see section [7. List of pumped liquids](#), page 81, or related CRT, CRTE data booklet available on Grundfos Product Center (<http://product-selection.grundfos.com/>).

Product range

Range	CR 1s	CR 1	CR 3	CR 5	CR 10	CR 15	CR 20
Rated flow rate [m ³ /h]	1	1.2	3.6	6	12	18	24
Liquid temperature [°C]	-20 - +120						
Liquid temperature [°C], on request	-40 - +180						
Maximum pump efficiency [%]	35	49	59	67	70	72	72
CR pumps							
Flow rate [m ³ /h]	0.4 - 1.3	0.8 - 2.9	1.4 - 5.4	3 - 10.2	6-16	10-29	13-35
Maximum pressure [bar]	23	24	24	24	25	24	21
High pressure [bar], on request (CRN)	-	48	42	48	47	47	47
Motor power [kW]	0.37 - 1.1	0.37 - 3.0	0.37 - 4.0	0.55 - 7.5	0.75 - 11	1.5 - 18.5	2.2 - 18.5
Version							
CR: Cast iron and stainless steel EN 1.4301/AISI 304	•	•	•	•	•	•	•
CRI: Stainless steel EN 1.4301/AISI 304	•	•	•	•	•	•	•
CRN: Stainless steel EN 1.4401/AISI 316	•	•	•	•	•	•	•
CRT: Titanium	See the CRT, CRTE data booklet available on Grundfos Product Center > http://product-selection.grundfos.com/ .						
CR pipe connection							
Oval flange (BSP)	Rp 1	Rp 1	Rp 1	Rp 1 1/4	Rp 1 1/2	Rp 2	Rp 2
Oval flange (BSP), on request	Rp 1 1/4	Rp 1 1/4	Rp 1 1/4	Rp 1	Rp 1 1/4 Rp 2	Rp 2 1/2	Rp 2 1/2
Flange	DN 25/ DN 32	DN 25/ DN 32	DN 25/ DN 32	DN 25/ DN 32	DN 40	DN 50	DN 50
Flange, on request	-	-	-	-	DN 50	-	-
CRI pipe connection							
Oval flange (BSP)	Rp 1	Rp 1	Rp 1 1/4	Rp 1 1/4	Rp 1 1/2	Rp 2	Rp 2
Oval flange (BSP), on request	Rp 1 1/4	Rp 1 1/4	Rp 1	Rp 1	Rp 2	-	-
Flange	DN 25/ DN 32	DN 25/ DN 32	DN 25/ DN 32	DN 25/ DN 32	DN 40	DN 50	DN 50
Flange, on request	-	-	-	-	DN 50	-	-
PJE coupling (Victaulic)	R 1 1/4 DN 32	R 1 1/4 DN 32	R 1 1/4 DN 32	R 1 1/4 DN 32	R 2 DN 50	R 2 DN 50	R 2 DN 50
Clamp coupling (L-coupling)	Ø42.2	Ø48.3	Ø48.3	Ø48.3	Ø60.3	Ø60.3	Ø60.3
Union (+GF+)	G 2	G 2	G 2	G 2	G 2 3/4	G 2 3/4	G 2 3/4
CRN pipe connection							
Oval flange (BSP)	Rp 1	Rp 1	Rp 1 1/4	Rp 1 1/4	Rp 1 1/2	Rp 2	Rp 2
Oval flange (BSP), on request	Rp 1 1/4	Rp 1 1/4	Rp 1	Rp 1	Rp 2	-	-
Flange	DN 25/ DN 32	DN 25/ DN 32	DN 25/ DN 32	DN 25/ DN 32	DN 40	DN 50	DN 50
Flange, on request	-	-	-	-	DN 50	-	-
PJE coupling (Victaulic)	R 1 1/4 DN 32	R 1 1/4 DN 32	R 1 1/4 DN 32	R 1 1/4 DN 32	R 2 DN 50	R 2 DN 50	R 2 DN 50
Clamp coupling (L-coupling)	Ø48.3	Ø48.3	Ø48.3	Ø48.3	Ø60.3	Ø60.3	Ø60.3
Union (+GF+)	G 2	G 2	G 2	G 2	G 2 3/4	G 2 3/4	G 2 3/4

- Standard.
- Available.

Range	CR 32	CR 45	CR 64	CR 95	CR 125	CR 155
Rated flow rate [m ³ /h]	38	54	77	115	150	185
Liquid temperature [°C]	-30 - +120 ¹⁾					
Liquid temperature [°C], on request	-40 - +180					
Maximum pump efficiency [%]	76	78	79	82.5	82.5	82.5
CR pumps						
Flow rate [m ³ /h]	18-48	26-70	36-102	58-150	75-190	90-230
Maximum pressure [bar]	27	26	18	38 ²⁾	38 ²⁾	38 ²⁾
High pressure [bar], on request (CRN)	49	49	34	-	-	-
Motor power [kW]	2.2 - 30	5.5 - 45	7.5 - 45	11-55	15-110	18.5 - 110
Version						
CR: Cast iron and stainless steel EN 1.4301/AISI 304	•	•	•	•	•	•
CRI: Stainless steel EN 1.4301/AISI 304	-	-	-	-	-	-
CRN: Stainless steel EN 1.4401/AISI 316	•	•	•	•	•	•
CRT: Titanium	See the CRT, CRTE data booklet available on Grundfos Product Center > http://product-selection.grundfos.com/ .					
CR pipe connection						
Oval flange (BSP)	-	-	-	-	-	-
Oval flange (BSP), on request	-	-	-	-	-	-
Flange	DN 65	DN 80	DN 100	DN 100	DN 150	DN 150
Flange, on request	DN 80	DN 100	DN 125	-	-	-
CRI pipe connection						
Oval flange (BSP)	-	-	-	-	-	-
Oval flange (BSP), on request	-	-	-	-	-	-
Flange	-	-	-	-	-	-
Flange, on request	-	-	-	-	-	-
PJE coupling (Victaulic)	-	-	-	-	-	-
Clamp coupling (L-coupling)	-	-	-	-	-	-
Union (+GF+)	-	-	-	-	-	-
CRN pipe connection						
Oval flange (BSP)	-	-	-	-	-	-
Oval flange (BSP), on request	-	-	-	-	-	-
Flange	DN 65	DN 80	DN 100	DN 100	DN 150	DN 150
Flange, on request	DN 80	DN 100	DN 125	-	-	-
PJE coupling (Victaulic)	3"	4"	4"	5"	6"	6"
Clamp coupling (L-coupling)	88.9	114.3	-	141.3	168.3	168.3
Union (+GF+)	-	-	-	-	-	-

- Standard.
- Available.

¹⁾ CRN 32 to 155 with HQQE shaft seal: -40 - +120 °C.

²⁾ CR pumps: Maximum operating pressure is 25 bar.

Pump

The CR pumps are non-self-priming, vertical multistage centrifugal pumps.

The pumps are available with a Grundfos or Siemens standard motor.

The pump consists of a base and a pump head. The chamber stack and the sleeve are secured between the base and the pump head by means of staybolts. The base has inlet and outlet ports on the same level (in line). All pumps are fitted with a maintenance-free mechanical shaft seal of the cartridge type.

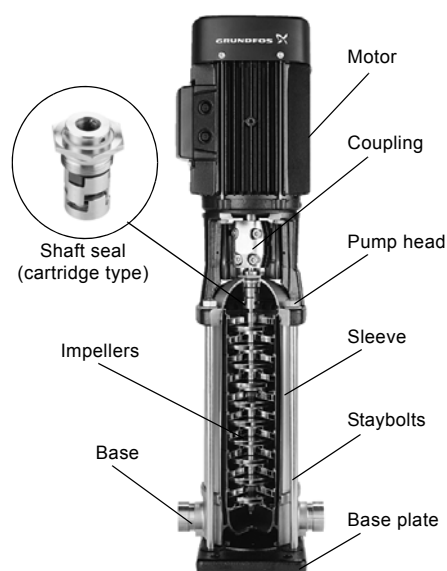

Fig. 4 CR pump

Motor

Grundfos MG standard and Siemens motors

CR, CRI and CRN pumps are fitted with totally enclosed, fan-cooled, 2-pole standard motors with principal dimensions to EN standards.

Electrical tolerances according to EN 60034.

CR, CRI, CRN pumps are fitted with three-phase MG motors as standard up to 22 kW and Siemens motors from 30 to 200 kW.

CR, CRI, CRN pumps from 0.37 to 2.2 kW are also available with single-phase motors (1 x 220-230/240 V). See Grundfos Product Center (<http://product-selection.grundfos.com/>).

Grundfos E-motors

We also offer frequency-controlled CRE, CRIE and CRNE pumps which are the ideal choice for a number of applications characterised by a demand for variable flow at constant pressure. These pumps are suited for water supply systems and pressure boosting as well as for industrial applications. Depending on the application, the pumps offer energy savings, increased comfort and improved processing.

See the CRE, CRIE and CRNE data booklet available on Grundfos Product Center (<http://product-selection.grundfos.com/>).

Electrical data

MG motor CR, CRI, CRN	
Mounting designation	Up to 4 kW: V18 From 5.5 kW: V1
Insulation class	F
Efficiency class	IE2 - IE3
Enclosure class	IP55 ¹⁾
Supply voltage	P2: 0.37 to 1.1 kW: 3 x 220-255/380-440 V
Tolerance: - 10 %/+ 10 %	P2: 1.5 kW: 3 x 220-277/380-480 V
	P2: 2.2 to 5.5 kW: 3 x 380-480 V
	P2: 7.5 to 22 kW: 3 x 380-480/660-690 V
	P2: 30 to 110 kW: 3 x 380-420/660-725 V
Supply frequency	60 Hz

¹⁾ IP44 and IP54 are available on request.

Optional motors

The Grundfos standard range of motors covers a wide variety of application demands. However, for special applications or operating conditions, custom-built motor solutions can be provided.

For special applications or operating conditions, we offer custom-built motors such as:

- ATEX-approved motors
- MG motors with anti-condensation heating unit
- motors with thermal protection.

Motor protection

MG and Siemens motors

Single-phase Grundfos motors have a built-in thermal overload switch (TP 211 according to IEC 34-11).

Three-phase motors must be connected to a motor-protective circuit breaker according to local regulations.

Three-phase Grundfos motors as from 3 kW have a built-in thermistor (PTC) according to DIN 44082 (TP 211 according to IEC 34-11).

GR6357 - GR3395

Terminal box positions

As standard, the terminal box is fitted on the suction side of the pump.

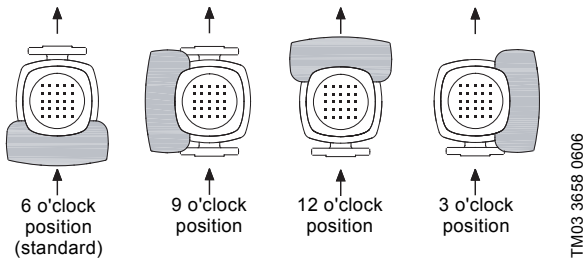

Fig. 5 Terminal box positions

TM03 3658 0606

Ambient temperature

Motor power [kW]	Motor make	Motor efficiency class	Maximum ambient temperature [°C]	Maximum altitude above sea level [m]
0.37 - 0.55	MG	-	40	1000
0.75 - 22	MG	IE3	60	3500
30-200	Siemens	IE3	55	2750

If the ambient temperature exceeds the above maximum temperatures or the pump is installed at an altitude exceeding the above altitude values, the motor must not be fully loaded due to the risk of overheating. Overheating may result from excessive ambient temperatures or the low density and consequently low cooling effect of the air.

In such cases, it may be necessary to use a motor with a higher rated output.

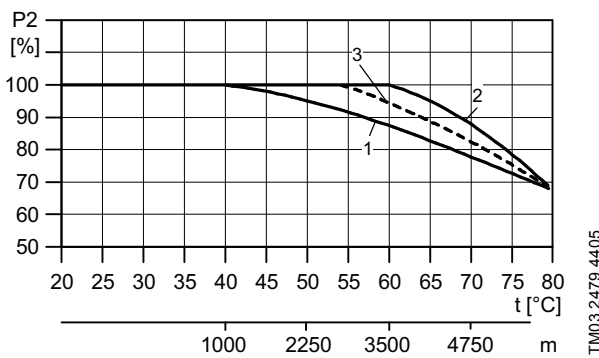

Fig. 6 Motor output in relation to temperature/altitude

TM03 2479 4405

Pos.	Motor power [kW]	Motor make
1	0.37 and 0.55	MG
2	0.75 - 22	MG
3	30-200	Siemens

Viscosity

The pumping of liquids with densities or kinematic viscosities higher than those of water will cause a considerable pressure drop, a drop in the hydraulic performance and a rise in the power consumption.

In such situations, the pump must be fitted with a larger motor. If in doubt, contact Grundfos.

2. Construction

CR 1s, 1, 3, 5, 10, 15 and 20



TM02 1198 0601 - GR7377 - GR7379

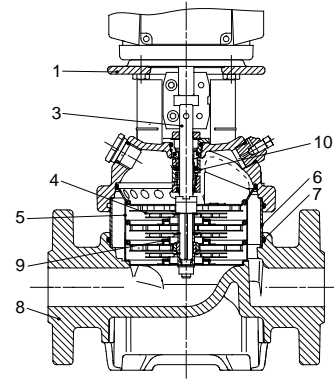

TM02 1194 1403

Materials, CR

Pos.	Designation	Materials	DIN/EN	≈ AISI/ASTM
1	Pump head	Grey cast iron	EN-GJL-200	ASTM 25B
3	Shaft	Stainless steel	EN10088 1.4401 ¹⁾ EN10088 1.4057 ²⁾	AISI 316 AISI 431
4	Impeller	Stainless steel	EN10088 1.4301	AISI 304
5	Chamber	Stainless steel	EN10088 1.4301	AISI 304
6	Sleeve	Stainless steel	EN10088 1.4301	AISI 304
7	O-ring for sleeve	EPDM or FKM	-	-
8	Base	Grey cast iron	EN-GJL-250	ASTM 25B
9	Neck ring	PTFE	-	-
10	Shaft seal (seal faces)	Silicon carbide/Silicon carbide	-	-
	Rubber parts	EPDM or FKM	-	-

¹⁾ CR 1s, 1, 3, 5.

²⁾ CR 10, 15, 20.

CRI 1s, 1, 3, 5, 10, 15 and 20



TM02 1808 2001 - GR7375

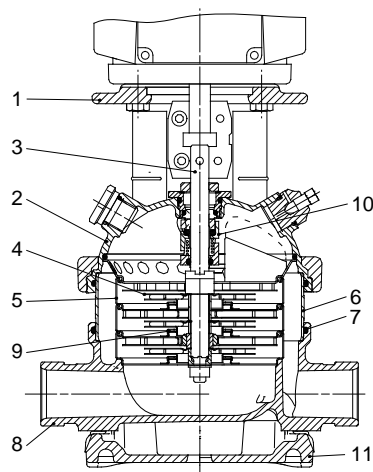

TM02 1195 1403

Materials, CRI

Pos.	Designation	Materials	DIN/EN	≈ AISI/ASTM
1	Motor stool	Grey cast iron ¹⁾	EN-GJL-200	ASTM 25B
2	Pump head cover	Stainless steel	EN10283 1.4408	CF 8M equal to AISI 316
3	Shaft	Stainless steel	EN10088 1.4401 ²⁾ EN10088 1.4057 ³⁾	AISI 316 AISI 329 AISI 431
4	Impeller	Stainless steel	EN10088 1.4301	AISI 304
5	Chamber	Stainless steel	EN10088 1.4301	AISI 304
6	Sleeve	Stainless steel	EN10088 1.4301	AISI 304
7	O-ring for sleeve	EPDM or FKM	-	-
8	Base	Stainless steel	EN10283 1.4408	CF 8M equal to AISI 316
9	Neck ring	PTFE	-	-
10	Shaft seal (seal faces)	Silicon carbide/Silicon carbide	-	-
11	Base plate	Grey cast iron ¹⁾	EN-GJL-200	ASTM 25B
	Rubber parts	EPDM or FKM	-	-

1) Stainless steel available on request.

2) CRI, 1s, 1, 3, 5.

3) CRI 10, 15, 20.

CRN 1s, 1, 3, 5, 10, 15 and 20



TM02 1808 2001 - GR7373

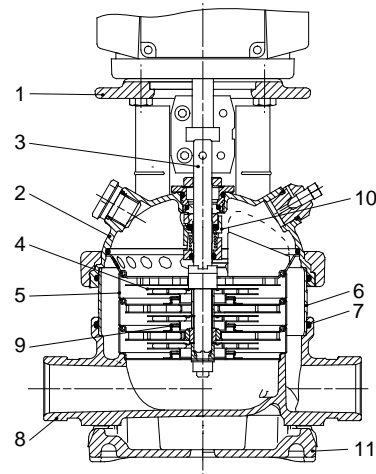

TM02 1195 1403

Materials, CRN

Pos.	Designation	Materials	DIN/EN	≈ AISI/ASTM
1	Pump head	Grey cast iron ¹⁾	EN-GJL-200	ASTM 25B
2	Pump head cover	Stainless steel	EN10283 1.4408	CF 8M equal to AISI 316
3	Shaft	Stainless steel	EN10088 1.4401 ²⁾ 1.4460 ³⁾	AISI 316 AISI 329 AISI 431
4	Impeller	Stainless steel	EN10088 1.4401	AISI 316
5	Chamber	Stainless steel	EN10088 1.4401	AISI 316
6	Sleeve	Stainless steel	EN10088 1.4401	AISI 316
7	O-ring for sleeve	EPDM or FKM	-	-
8	Base	Stainless steel	EN10283 1.4408	CF 8M equal to AISI 316
9	Neck ring	PTFE	-	-
10	Shaft seal (seal faces)	Silicon carbide/Silicon carbide	-	-
11	Base plate	Grey cast iron ¹⁾	EN-GJL-200	ASTM 25B
	Rubber parts	EPDM or FKM	-	-

¹⁾ Stainless steel available on request.

²⁾ CRN 1s, 1, 3, 5.

³⁾ CRN 10, 15, 20.

CR 32, 45 and 64



TM01 2150 1298

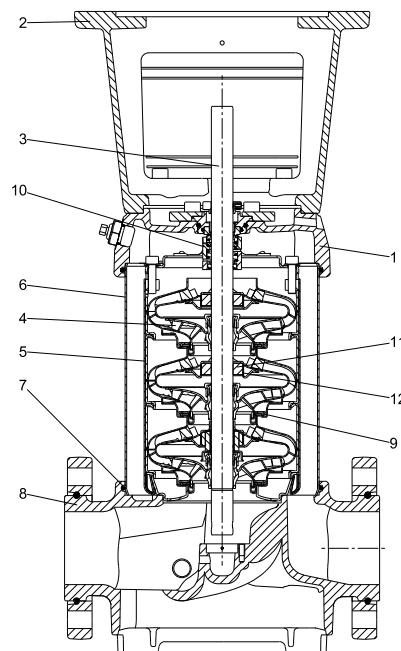

TM06 0711 0814

Materials, CR

Pos.	Designation	Materials	DIN/EN	≈ AISI/ASTM
1	Pump head cover	Ductile cast iron	EN-GJS-500-7	ASTM A536 70-50-05
2	Motor stool	Grey cast iron	EN-GJL-200	ASTM 25B
3	Shaft	Stainless steel	EN10088 1.4057	AISI 431
4	Impeller	Stainless steel	EN10088 1.4301	AISI 304
5	Chamber	Stainless steel	EN10088 1.4301	AISI 304
6	Sleeve	Stainless steel	EN10088 1.4301	AISI 304
7	O-ring for sleeve	EPDM or FKM	-	-
8	Base	Ductile cast iron	EN-GJS-500-7	ASTM A536 70-50-05
9	Neck ring	Carbon-graphite- filled PTFE	-	-
10	Shaft seal (seal faces)	Silicon carbide/Silicon carbide	-	-
11	Bearing ring	Silicon carbide/Silicon carbide	-	-
12	Support bearing	Carbon-graphite- filled PTFE	-	-
13	Base plate	Ductile cast iron	EN-GJS-500-7	ASTM A536 70-50-05
	Rubber parts	EPDM or FKM	-	-

CRN 32, 45 and 64



TM06 9503 2417

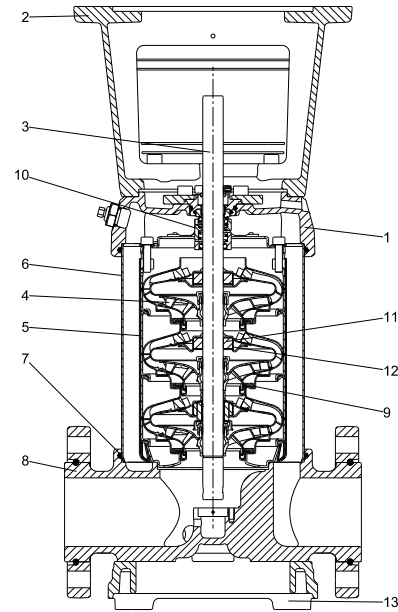

TM06 0712 0814

Materials, CRN

Pos.	Designation	Materials	DIN/EN	≈ AISI/ASTM
1	Pump head cover	Stainless steel	EN10283 1.4408	CF 8M equal to AISI 316
2	Motor stool	Grey cast iron ¹⁾	EN-GJL-200	ASTM 25B
3	Shaft	Stainless steel	EN10088 1.4462	-
4	Impeller	Stainless steel	EN10088 1.4401	AISI 316
5	Chamber	Stainless steel	EN10088 1.4401	AISI 316
6	Sleeve	Stainless steel	EN10088 1.4401	AISI 316
7	O-ring for sleeve	EPDM or FKM	-	-
8	Base	Stainless steel	EN10283 1.4408	CF 8M equal to AISI 316
9	Neck ring	Carbon-graphite- filled PTFE	-	-
10	Shaft seal (seal faces)	Silicon carbide/Silicon carbide	-	-
11	Bearing ring	Silicon carbide/Silicon carbide	-	-
12	Support bearing	Carbon-graphite- filled PTFE	-	-
13	Base plate	Ductile cast iron ¹⁾	EN-GJS-500-7	ASTM A536 70-50-05
	Rubber parts	EPDM or FKM	-	-

¹⁾ Stainless steel available on request.

CR 95, 125, 155



DIN flange

TM06 9206 1917

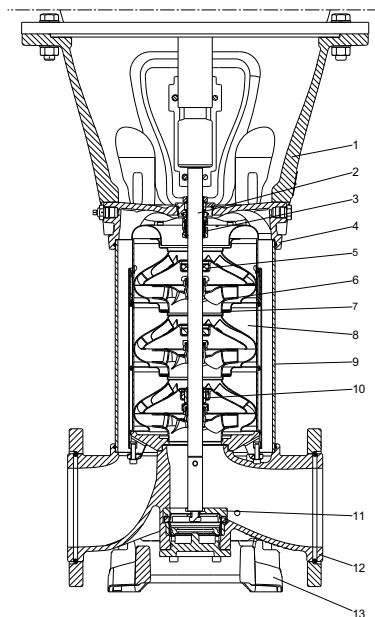

TM06 5161 1917

Materials, CR

Pos.	Designation	Materials	DIN/EN	≈ AISI/ASTM
1	Motor stool	Ductile cast iron	EN-GJS-500-7	ASTM A536-84 70-50-05
2	Shaft	Stainless steel	EN10088 1.4057 ¹⁾ EN10088 1.4462 ²⁾	EN10088 1.4057=431 EN10088 1.4462=318 LN
3	Shaft seal (seal faces)	Silicon carbide/Silicon carbide	-	-
4	Pump head cover	Ductile cast iron	EN-GJS-500-7	ASTM A536-84 70-50-05
5	Support bearing (bush)	Carbon-graphite filled PTFE	-	-
6	Impeller	Stainless steel	EN10088 1.4301 EN 10088 1.4401	AISI 304
7	Neck ring	PEEK	-	-
8	Chamber	Stainless steel	EN10088 1.4301 EN 10088 1.4401	AISI 304
9	Sleeve	Stainless steel	EN10088 1.4301 ¹⁾ EN10088 1.4404 ²⁾	AISI 304 ¹⁾ AISI 316 L ²⁾
10	Bearing ring	Tungsten carbide/Tungsten carbide	-	-
11	Thrust handling device ³⁾	Stainless steel	EN10088 1.4401 EN10283 1.4408	AISI 316/CF 8M
		Silicon carbide/Tungsten carbide	-	-
12	Base	Ductile cast iron	EN-GJS-500-7	ASTM A536-84 70-50-05
13	Base plate	Ductile cast iron	EN-GJS-500-7	ASTM A536-84 70-50-05
	Rubber parts	EPDM or FKM	-	-

¹⁾ Applies to CR 95.

²⁾ Applies to CR 125 to CR 155.

³⁾ Only fitted on pumps with 75 kW motors or larger.

CRN 95, 125, 155



Collar flange

DIN flange

Victaulic type (PJE)

TM06 9203 1917 - TM06 9208 1917 - TM06 9210 1917

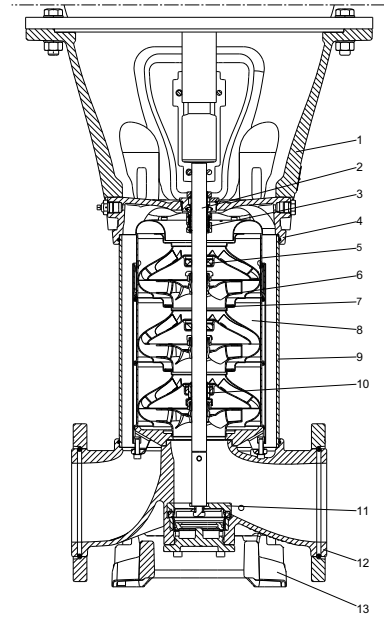

TM06 5161 1917

Materials, CRN

Pos.	Designation	Materials	DIN/EN	≈ AISI/ASTM
1	Motor stool	Ductile cast iron	EN-GJS-500-7	ASTM A536-84 70-50-05
2	Shaft	Stainless steel	EN10088 1.4462	318 LN
3	Shaft seal (seal faces)	Silicon carbide/Silicon carbide	-	-
4	Pump head cover	Stainless steel	EN10283 1.4408	CF 8M
5	Support bearing (bush)	Carbon-graphite filled PTFE	-	-
6	Impeller	Stainless steel	EN10088 1.4401	AISI 316
7	Neck ring	PEEK	-	-
8	Chamber	Stainless steel	EN10088 1.4401	AISI 316
9	Sleeve	Stainless steel	EN10088 1.4404	AISI 316 L
10	Bearing ring	Tungsten carbide/Tungsten carbide	-	-
11	Thrust handling device ¹⁾	Stainless steel	EN10088 1.4401	AISI 316/CF 8M
		Silicon carbide/Tungsten carbide	-	
12	Base	Stainless steel	EN10283 1.4408	CF 8M
13	Base plate	Ductile cast iron	EN-GJS-500-7	ASTM A536-84 70-50-05
	Rubber parts	EPDM or FKM	-	-

¹⁾ Only fitted on pumps with 75 kW motors or larger.

Type key

Example	CR	E	32	s	-4	-2	-A	-F	-G	-E	-HQQE
Type range: CR, CRI, CRN, CRT											
Pump with integrated frequency converter											
Flow rate [m ³ /h]											
Undersize impeller (all impellers) CR 1s, CRI 1s, CRN 1s											
Number of impellers											
Number of reduced-diameter impellers CR, CRE, CRN, CRNE 32, 45, 64											
Code for pump version											
Code for pipe connection											
Code for materials											
Code for rubber parts											
Code for shaft seal											

Key to codes

Code	Description
Pump version	
A	Basic version
B	Oversize motor
C	CR compact
D	Pump with pressure intensifier*
E	Pump with certificate
F	Pump for high temperatures (with air-cooled top)
G	E-pump without control panel
H	Horizontal version
I	Different pressure rating
J	E-pump with a different maximum speed
K	Pump with low NPSH
L	Pump including Grundfos CUE and certificate
M	Magnetic drive
N	With sensor
O	Cleaned and dried
P	Undersize motor
Q	High-pressure pump with high-speed MGE motor*
R	Belt driven pump
S	High-pressure pump
T	Thrust handling device*
U	ATEX approved pump
V	Cascade function
W	Deep-well pump with ejector*
X	Special version
Y	Electropolished
Z	Pumps with bearing flange
Pipe connection	
A	Oval flange
B	NPT thread
CA	FlexiClamp
CX	Triclamp*
F	DIN flange
FC	DIN 11853-2 flange (collar flange)
FE	EN 1092-1, type E
G	ANSI flange
J	JIS flange
N	Changed diameter of ports
P	PJE coupling (Victaulic type)
X	Special version

Code	Description
Materials	
A	Basic version
C	Carbon free pump
D	Carbon-graphite filled PTFE (bearings)/Tungsten carbide
E	Pickled and passivated (Only Japan)
H	Flanges and base plate EN 1.4408
K	Bronze (bearings)/Tungsten carbide
L	Motor stool, base plate and flanges EN 1.4408
M	Motor stool, base plate, coupling and flanges EN 1.4408 and coupling guards in cobber. Bolts, nuts and spacing pipes EN 1.4401 or higher grade
N	Flanges EN 1.4408
P	PEEK neck ring
Q	Silicon carbide/Silicon carbide bearing in pump and Silicon carbide/Silicon carbide seal faces in thrust handling device
R	Silicon carbide/Silicon carbide bearing
S	PTFE neck rings
T	Base plate EN 1.4408
U	Silicon carbide/Silicon carbide bearing in pump and Silicon carbide/Tungsten carbide seal faces in thrust handling device
X	Special version

Code for rubber parts in pump	
E	EPDM
F	FXM (Fluoraz [®])
K	FFKM (Kalrez [®])
N	Neoprene
V	FKM (Viton [®])

Shaft seal type designation	
A	O-ring seal with fixed driver*
H	Balanced cartridge seal with O-ring
O	Double seal, back-to-back*
P	Double seal, tandem*
X	Special version*

Seal face material	
B	Carbon, synthetic resin-impregnated
U	Cemented tungsten carbide
Q	Silicon carbide
X	Other ceramics*

Secondary seal material (rubber parts)	
E	EPDM
F	FXM (Fluoraz [®])
K	FFKM (Kalrez [®])
V	FKM (Viton [®])

* Option. See the CR "Custom-built pumps" data booklet available on Grundfos Product Center. See QR code or link below.



<http://net.grundfos.com/qr/i/96486346>

Shaft seal

Example	-H	-Q	-Q	-E
Shaft seal type designation				
Material of rotating seal face				
Material of stationary seal face				
Material of secondary seal (rubber parts)				

3. Operating and inlet pressures

Maximum operating pressure and liquid temperature

Pump type	Oval flange		PJE, clamp, union, DIN	
	Maximum permissible operating pressure [bar]	Liquid temperature [°C]	Maximum permissible operating pressure [bar]	Liquid temperature [°C]
CR, CRI, CRN 1s	16	-20 - +120	25	-20 - +120
CR, CRI, CRN 1	16		25	
CR, CRI, CRN 3	16		25	
CR, CRI, CRN 5	16		25	
CR, CRI 10-1 → 10-10	16	-	16	-
CR, CRI 10-12 → 10-17	-		25	
CRN 10	16	-20 - +120	25	-
CR, CRI 15-1 → 15-5	10	-	16	
CR, CRI 15-1 → 15-8	-	-	25	-20 - +120
CR, CRI 15-9 → 15-12	-	-	25	
CRN 15	10	-20 - +120	25	-
CR, CRI 20-1 → 20-5	10	-	16	
CR, CRI 20-1 → 20-7	-	-	25	-20 - +120
CR, CRI 20-8 → 20-10	-	-	25	
CRN 20	10	-20 - +120	25	-
CR, CRN 32-1-1 → 32-5	-	-	16	
CR, CRN 32-6-2 → 32-10-2	-	-	30	-30 - +120
CR, CRN 45-1-1 → 45-4	-	-	16	
CR, CRN 45-5-2 → 45-7	-	-	30	-
CR, CRN 64-1-1 → 64-3	-	-	16	
CR, CRN 64-4-2 → 64-5-2	-	-	30	-40 to +120
CR, CRN 95-1-1 → 95-4-2	-	-	16	
CR, CRN 95-4 → 95-5-3	-	-	25	-
CR, CRN 125-1-1 → 125-3	-	-	16	
CRN 125-4 → 125-5	-	-	25	-
CR, CRN 155-1-1 → 155-3-3	-	-	16	
CRN 155-3-1 → 155-5-3	-	-	25	

For pump sizes 32, 45, 64, the max. pressure for PJE is 50 bar and only available in CRN version.

Operating range of the shaft seal

All pumps will be delivered with a HQQE/V cartridge shaft seal as standard.

The operating range of the shaft seal depends on operating pressure, pump type, type of shaft seal and liquid temperature. The range shown in figs 7 and 8 applies to clean water and water with anti-freeze liquids. For selection of the right shaft seal, see section 7. *List of pumped liquids*, page 81. If the operating range is exceeded, the life of the shaft seal may be reduced.

Note that if you pump demineralised water with a conductivity below 2 µS/cm with a pump equipped with a silicon carbide/silicon carbide shaft seal, there is an increased risk of electro corrosion. We recommend that you use a silicon carbide/carbon or silicon carbide/tungsten carbide shaft seal instead.

Optional shaft seals

See section 9. *Variants*, page 93 for optional shaft seal solutions.

CR, CRI, CRN 1s-155

Shaft seals for Ø12, Ø16 and Ø22 shafts (0.37 - 55 kW)

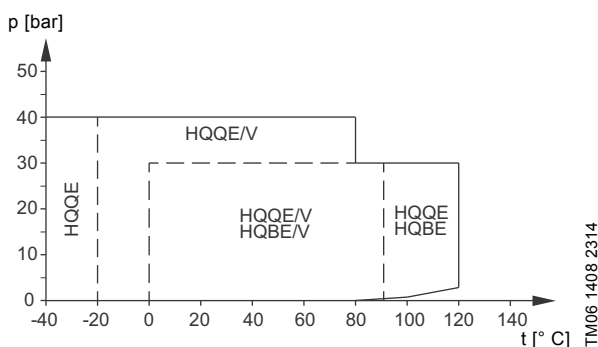

Fig. 7 Operating range of standard shaft seals for CR, CRI, CRN 1-155

Standard shaft seal	Motor size [kW]	Description	Liquid temperature [°C]
HQQE	0.37 - 55	O-ring (cartridge) (balanced seal), Silicon carbide/Silicon carbide, EPDM	-40 - +120
HQQV		O-ring (cartridge) (balanced seal), Silicon carbide/Silicon carbide, FKM	-20 - +90
HQBE		O-ring (cartridge) (balanced seal), Silicon carbide/carbon, EPDM	0 - +120
HQBV		O-ring (cartridge) (balanced seal), Silicon carbide/carbon, FKM	0 - +90

Shaft seals for Ø28 (75-110 kW) shaft ends

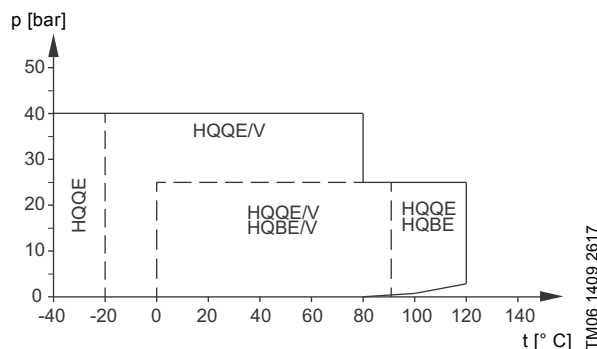

Fig. 8 Operating range of standard shaft seals for Ø28 shaft ends (75-110 kW)

Standard shaft seal	Motor size [kW]	Description	Liquid temperature [°C]
HQQE	75-110	O-ring (cartridge) (balanced seal), Silicon carbide/Silicon carbide, EPDM	-40 - +120
HQQV		O-ring (cartridge) (balanced seal), Silicon carbide/Silicon carbide, FKM	-20 - +90
HQBE		O-ring (cartridge) (balanced seal), Silicon carbide/carbon, EPDM	0 - +120
HQBV		O-ring (cartridge) (balanced seal), Silicon carbide/carbon, FKM	0 - +90

Maximum inlet pressure

The following table shows the maximum permissible inlet pressure. However, the actual inlet pressure plus the pressure against a closed valve must always be lower than the maximum permissible operating pressure.

If the maximum permissible operating pressure is exceeded, the conical bearing in the motor may be damaged and the life of the shaft seal reduced.

Pump type	Maximum inlet pressure [bar]
CR, CRI, CRN 1s	
1s-2 → 1s-27	10
CR, CRI, CRN 1	
1-2 → 1-25	10
1-27	15
CR, CRI, CRN 3	
3-2 → 3-17	10
3-19 → 3-25	15
CR, CRI, CRN 5	
5-2 → 5-9	10
5-10 → 5-24	15
CR, CRI, CRN 10	
10-1 → 10-5	8
10-6 → 10-17	10
CR, CRI, CRN 15	
15-1 → 15-2	8
15-3 → 15-12	10
CR, CRI, CRN 20	
20-1	8
20-2 → 20-10	10
CR, CRN 32	
32-1-1 → 32-2	4
32-3-2 → 32-6	10
32-7-2 → 32-10-2	15
CR, CRN 45	
45-1-1 → 45-1	4
45-2-2 → 45-3	10
45-4-2 → 45-7	15
CR, CRN 64	
64-1-1	4
64-1 → 64-2-1	10
64-2 → 64-5-2	15
CR, CRN 95	
95-1- → 95 1-1	10
95-2 → 95-3-2	15
95-4 → 95-5-3	20
CR, CRN 125	
125-1 → 125-2-2	10
125-2 → 125-4	15
125-5 → 125-6	20
CR, CRN 155	
155-1 → 155-1-1	10
155-2 → 155-3-3	15

Examples of operating and inlet pressures

The values for operating and inlet pressures shown in the table should not be considered individually and should always be compared. See the following examples.

Example 1

The following pump type has been selected: CR 3-10 A-A-A.

Maximum operating pressure: 16 bar.

Maximum inlet pressure: 10 bar.

Discharge pressure against a closed valve: 9.6 bar.

See page 36.

This pump is **not** allowed to start at an inlet pressure of 10 bar, but at an inlet pressure of $16.0 - 9.6 = 6.4$ bar.

Example 2

The following pump type has been selected: CR 10-2 A-A-A

Maximum operating pressure: 16 bar.

Maximum inlet pressure: 8.0 bar.

Discharge pressure against a closed valve: 2.9 bar.

See page 44.

This pump is allowed to start at an inlet pressure of 8.0 bar, as the discharge pressure against a closed valve is only 2.9 bar. This results in an operating pressure of $8.0 + 2.9 = 10.9$ bar. On the contrary, the maximum operating pressure of this pump is limited to 16 bar as a higher operating pressure will require an inlet pressure of more than 8.0 bar.

If the inlet or operating pressure exceeds the pressure permitted, see section 9. *Variants*, page 93.

4. Selection and sizing

Selection of pumps

Selection of pumps should be based on these parameters:

- the duty point of the pump (see below)
- dimensional data such as pressure loss as a result of height differences, friction loss in the pipework, pump efficiency (see below)
- pump materials (see page 24)
- pump connections (see page 24)
- shaft seal (see page 24).

Duty point of the pump

From a duty point, it is possible to select a pump on the basis of the curve charts in section 5. *Performance curves and technical data*, page 28.

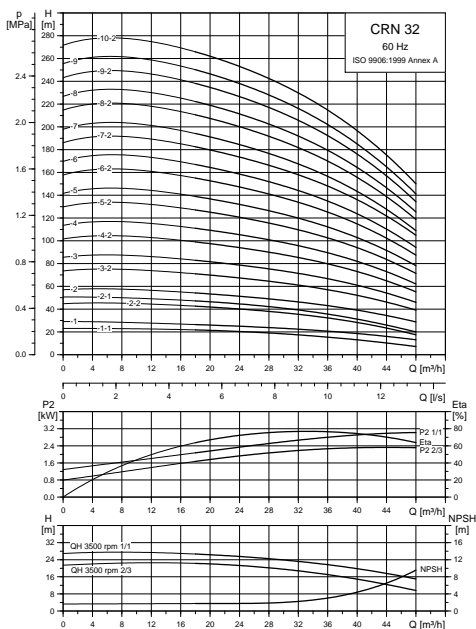

Fig. 9 Example of a curve chart

Sizing data

When sizing a pump, take these parameters into account:

- Required flow and pressure at the draw-off point.
- Pressure loss as a result of height differences (H_{geo}).
- Friction loss in the pipes (H_f).
- Best efficiency at the estimated duty point.
- NPSH value.

For calculation of the NPSH value, see *Minimum inlet pressure, NPSH*, page 25.

Pump efficiency

Before determining the best efficiency point, identify the operation pattern of the pump. If the pump is expected to operate at the same duty point, select a CR pump which is operating at a duty point corresponding to the best efficiency of the pump.

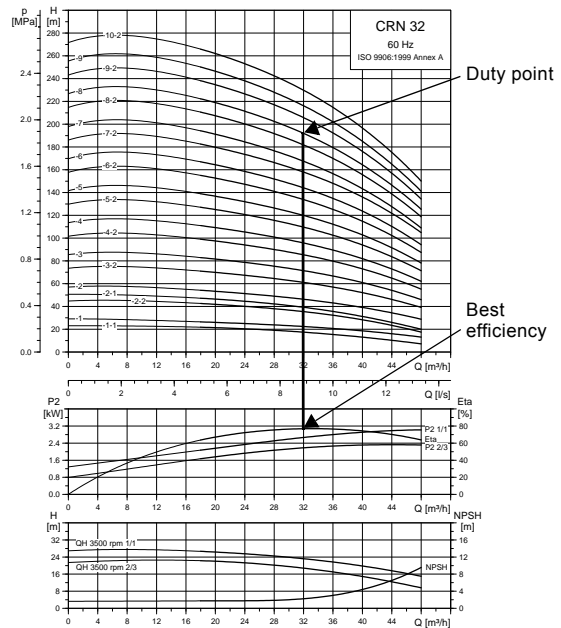

Fig. 10 Example of a CR pump's duty point

As the pump is sized on the basis of the highest possible flow, it is important always to have the duty point to the right on the efficiency curve (eta) in order to keep the efficiency high when the flow drops.

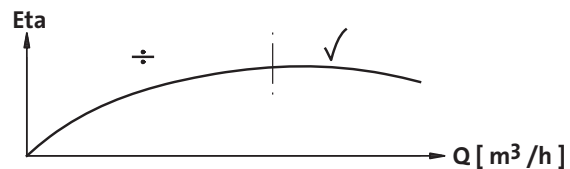

Fig. 11 Best efficiency

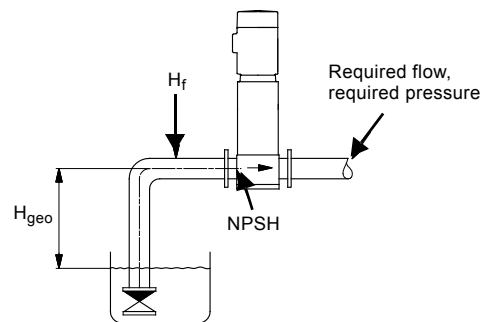

Fig. 12 Dimensional data

TM02 7323 3103

TM02 7323 3103

TM00 9190 1303

TM02 6711 1403

Pump material

Select the material variant on the basis of the liquid to be pumped.

The product range covers the following three basic types:

- CR, CRI
Use CR, CRI pumps for clean, non-aggressive liquids, such as potable water and oils.
- CRN
Use CRN pumps for industrial liquids and acids. See section 7. *List of pumped liquids*, page 81, or contact Grundfos.

For saline or chloride-containing liquids such as sea water, CRT pumps of titanium are available.

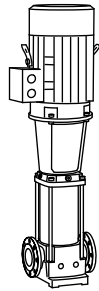

Fig. 13 CR pump

Pump connections

Selection of pump connection depends on the rated pressure and the pipes. To meet any requirement, the CR, CRI and CRN pumps offer a wide range of flexible connections, such as

- oval flange (BSP)
- DIN flange
- PJE coupling
- clamp coupling
- union (+GF+)
- other connections on request.

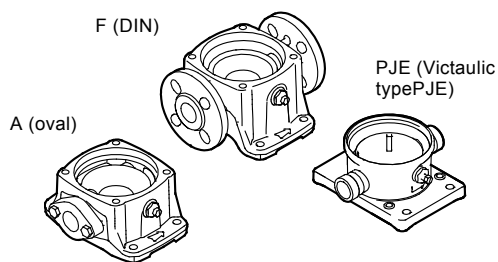

Fig. 14 Pump connections

Shaft seal



Fig. 15 Shaft seal (cartridge type)

As standard, the CR range is fitted with a Grundfos shaft seal (cartridge type) suitable for the most common applications.

These key parameters must be taken into account when selecting the shaft seal:

- type of pumped liquid
- liquid temperature
- maximum pressure.

We offer a wide range of shaft seal variants to meet specific demands. See section 7. *List of pumped liquids*, page 81.

Servicing shaft seals

Replacement shaft seals are available as complete service kits*.

Shaft seals fitted on CR, CRN 95-155 pumps with $\varnothing 28$ mm or $\varnothing 36$ mm shaft ends are serviceable. This means that the wear parts in these shaft seals are available as service kits* and can be replaced without having to renew the complete shaft seal.

* All service kits include detailed instructions on how to carry out the replacement.

TM01 2100 1198

TM02 1201 0601

GR7386

Thrust handling device

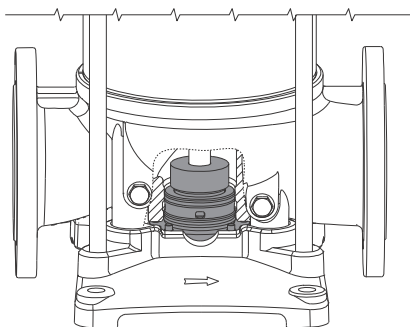

TM06 9669 2817

Fig. 16 Thrust handling device

A thrust handling device (THD) is factory-fitted on pumps with 75 kW motors or larger. The system consists of two parts. A rotating part mounted on the shaft end below the first impeller as well as a non-rotating part mounted in or on the pump base. The THD absorbs the main part of the thrust force generated by the impellers and thereby reduces the resulting axial force the motor bearings must absorb. This enables the use of standard ball bearings in the motor instead of special angular contact ball bearings.

Note: For applications involving CIP (cleaning-in-place) and motors above 55 kW, use a bearing flange and a base without THD.

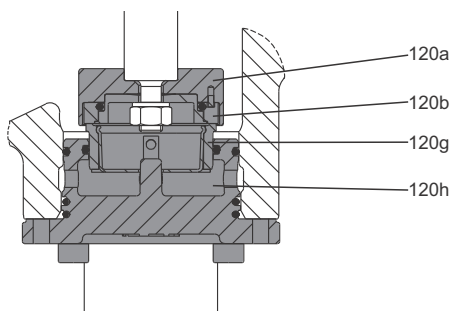

TM06 9670 2817

Fig. 17 Position numbers for THD parts

Pos.	Description	Material
120a	Thrust disc	Stainless steel
120b	Rotating ring	Silicon carbide
120g	Stationary ring	Silicon carbide* Tungsten carbide
120h	Lifting plate	Stainless steel
-	O-rings	EPDM FKM

* On request for CRN.

Operating pressure and inlet pressure

Do not exceed the limit values for these pressures:

- maximum operating pressure (page 15)
- maximum inlet pressure (page 22).

Minimum inlet pressure, NPSH

Calculation of the inlet pressure "H" is recommended in these situations:

- The liquid temperature is high.
- The flow is significantly higher than the rated flow.
- Water is drawn from depths.
- Water is drawn through long pipes.
- Inlet conditions are poor.

To avoid cavitation, make sure that there is a minimum pressure on the suction side of the pump.

The maximum suction lift "H" in metres head can be calculated as follows:

$$H = p_b \times 10.2 - \text{NPSH} - H_f - H_v$$

p_b	= Barometric pressure in bar. Barometric pressure can be set to 1 bar. In closed systems, p_b indicates the system pressure in bar.
NPSH	= Net Positive Suction Head in metres head. To be read from the NPSH curve at the highest flow the pump will be delivering.
H_f	= Friction loss in suction pipe in metres head. At the highest flow the pump will be delivering.
H_v	= Vapour pressure in metres head. To be read from the vapour pressure scale. H_v depends on the liquid temperature t_m .

If the calculated "H" is positive, the pump can operate at a suction lift of maximum "H" metres head.

If the calculated "H" is negative, an inlet pressure of minimum "H" metres head is required.

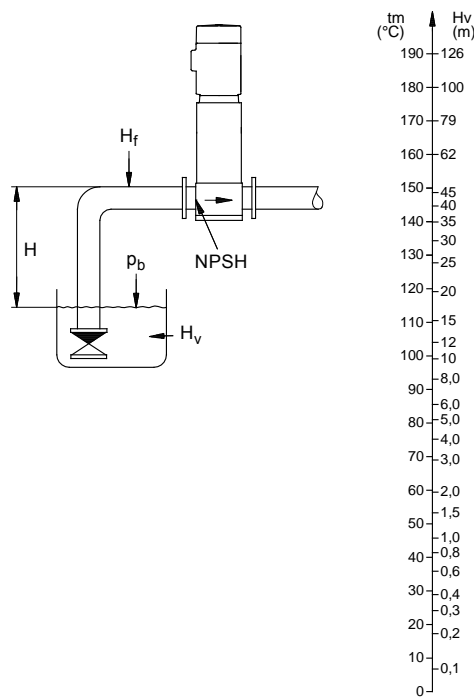

TM02 7439 3403

Fig. 18 Minimum inlet pressure, NPSH

Note: To avoid cavitation, do not select a pump with a duty point too far to the right on the NPSH curve. Always check the NPSH value of the pump at the highest possible flow.

How to read the curve charts

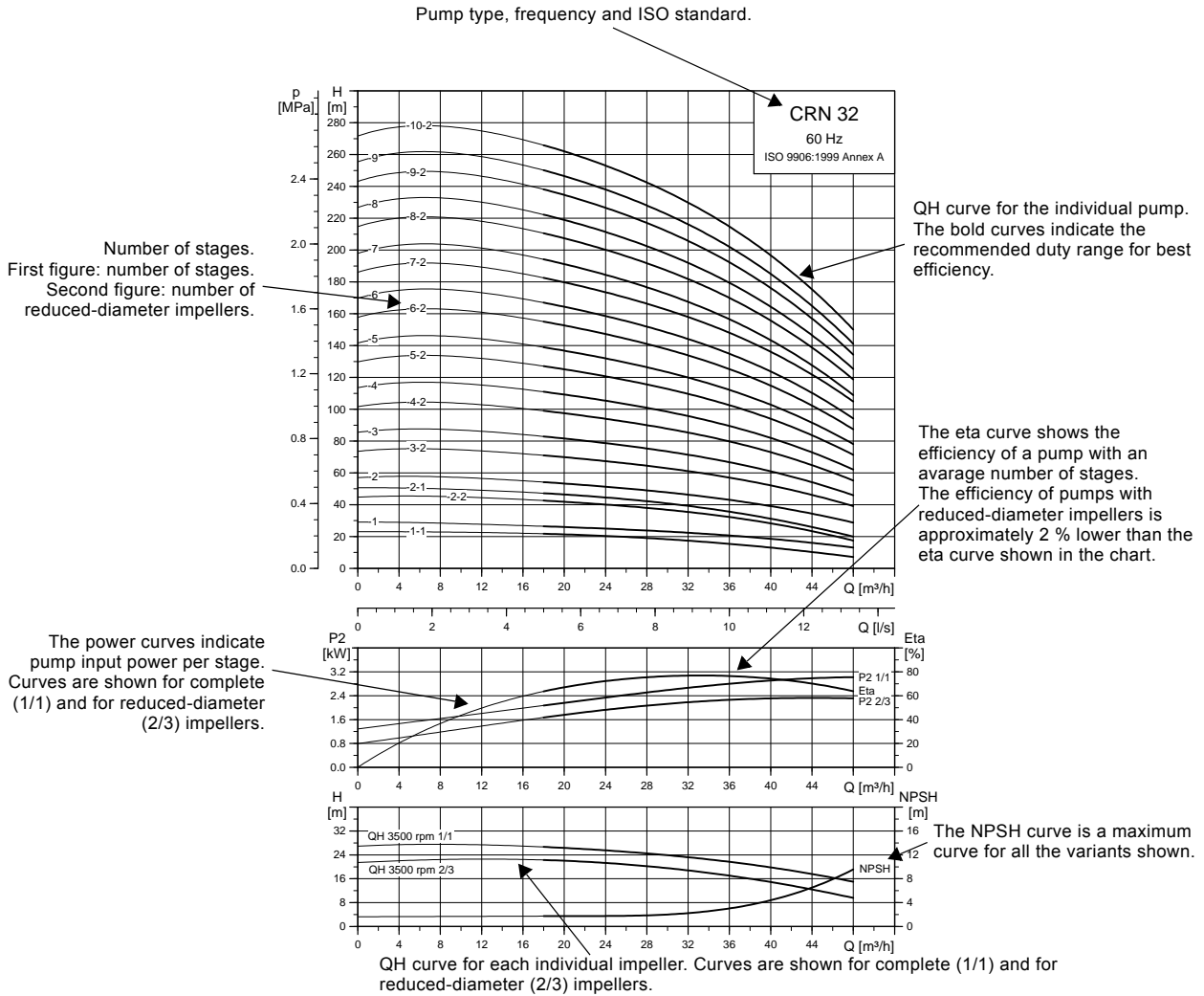

Fig. 19 How to read the curve charts

TM02 7323 0718

Guidelines to performance curves

The guidelines below apply to the curves shown on the following pages:

- Tolerances to ISO 9906:2012, Grade 3B, if indicated.
- The motors used for the measurements are standard Grundfos MG motors.
- Measurements have been made with airless water at a temperature of 20 °C.
- The curves apply to the following kinematic viscosity: $\nu = 1 \text{ mm}^2/\text{s}$ (1 cSt).
- Due to the risk of overheating, the pumps must not be used at a flow rate below the minimum flow rate.
- The QH curves apply to a rated motor speed of a three-phase mains-operated motor. For realistic curves, go to Grundfos Product Center (<http://product-selection.grundfos.com/>) and insert data.

The curve below shows the minimum flow rate as a percentage of the rated flow rate in relation to the liquid temperature. The dotted line shows a CR pump fitted with an air-cooled top assembly.

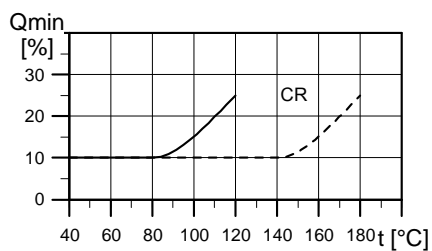

TM01 2816 0303

Fig. 20 Minimum flow rate

5. Performance curves and technical data

CR 1s

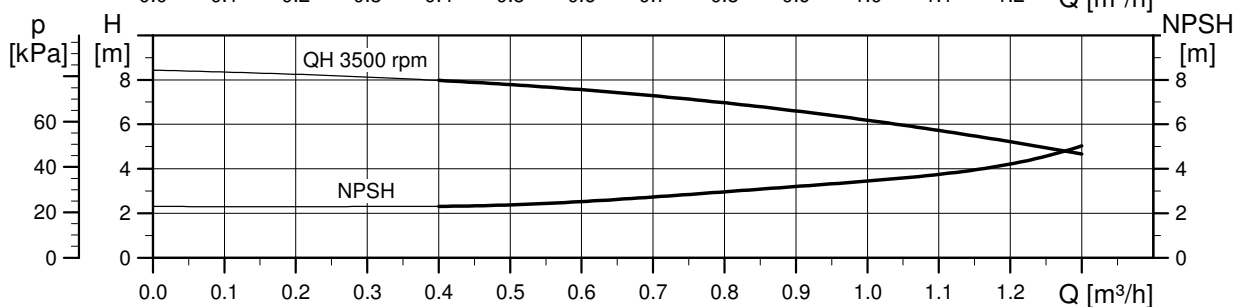
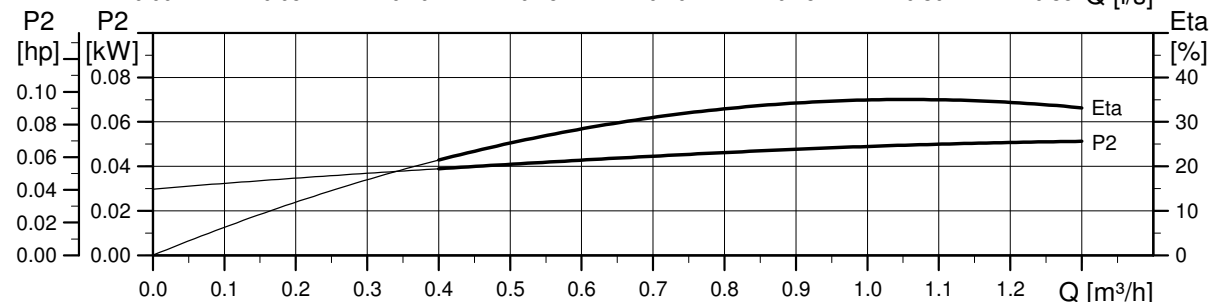
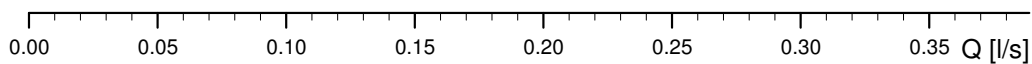
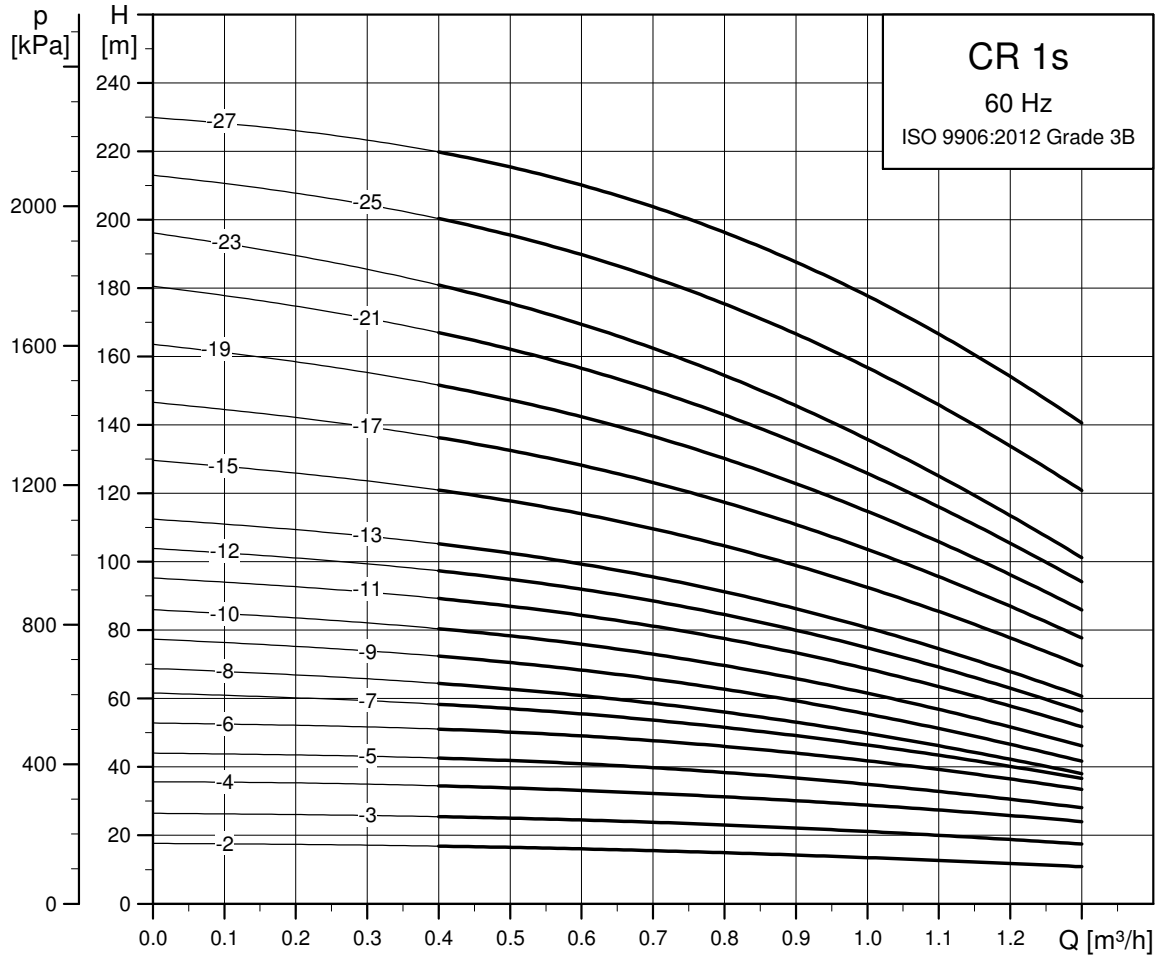

TM02 7422 09/18

Dimensional sketch

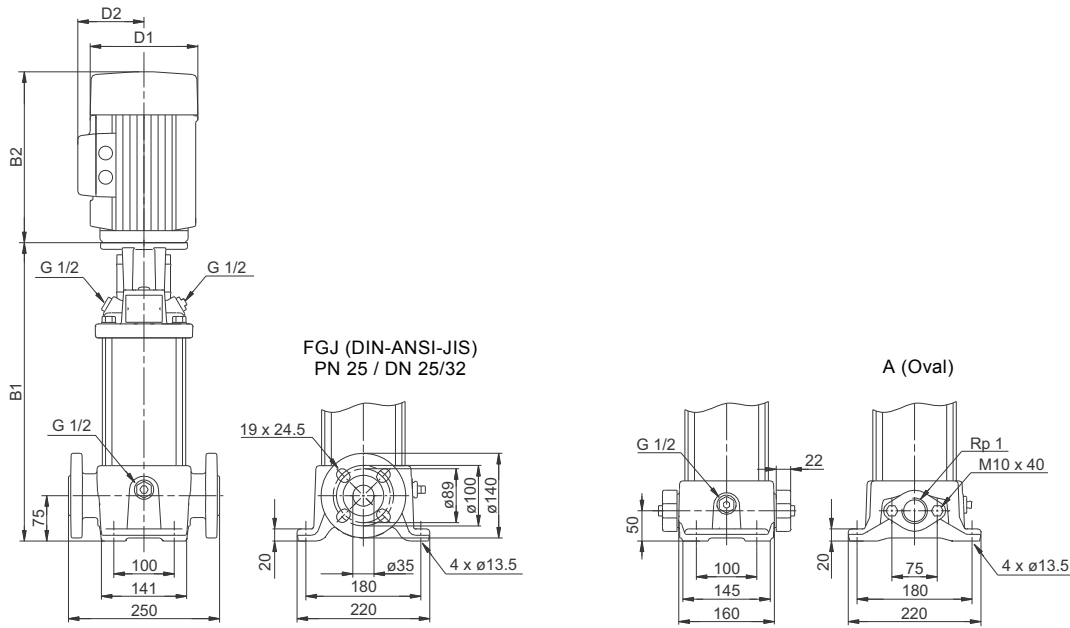

TM06 9591 2517

Dimensions and weights

Pump type	Motor P ₂ [kW]	Dimension [mm]				Net weight [kg]			
		Oval flange		DIN flange		D1	D2	Oval flange	DIN flange
B1	B1+B2	B1	B1+B2						
CR 1s-2	0.37	254	445	279	470	141	109	18	23
CR 1s-3	0.37	254	445	279	470	141	109	18	23
CR 1s-4	0.37	272	463	297	488	141	109	19	23
CR 1s-5	0.37	290	481	315	506	141	109	19	24
CR 1s-6	0.37	308	499	333	524	141	109	19	24
CR 1s-7	0.37	326	517	351	542	141	109	20	24
CR 1s-8	0.55	344	535	369	560	141	109	21	25
CR 1s-9	0.55	362	553	387	578	141	109	21	26
CR 1s-10	0.55	380	571	405	596	141	109	22	26
CR 1s-11	0.75	404	635	429	660	141	109	24	28
CR 1s-12	0.75	422	653	447	678	141	109	24	29
CR 1s-13	0.75	440	671	465	696	141	109	25	29
CR 1s-15	1.1	476	727	501	752	141	109	28	32
CR 1s-17	1.1	512	763	537	788	141	109	28	33
CR 1s-19	1.1	-	-	573	824	141	109	-	34
CR 1s-21	1.1	-	-	609	860	141	109	-	35
CR 1s-23	1.5	-	-	661	942	178	110	-	42
CR 1s-25	1.5	-	-	697	978	178	110	-	43
CR 1s-27	1.5	-	-	733	1014	178	110	-	44

CRI, CRN 1s

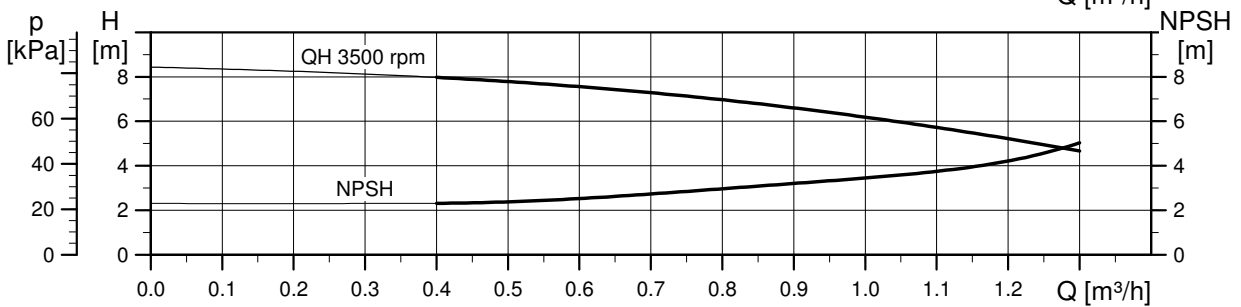
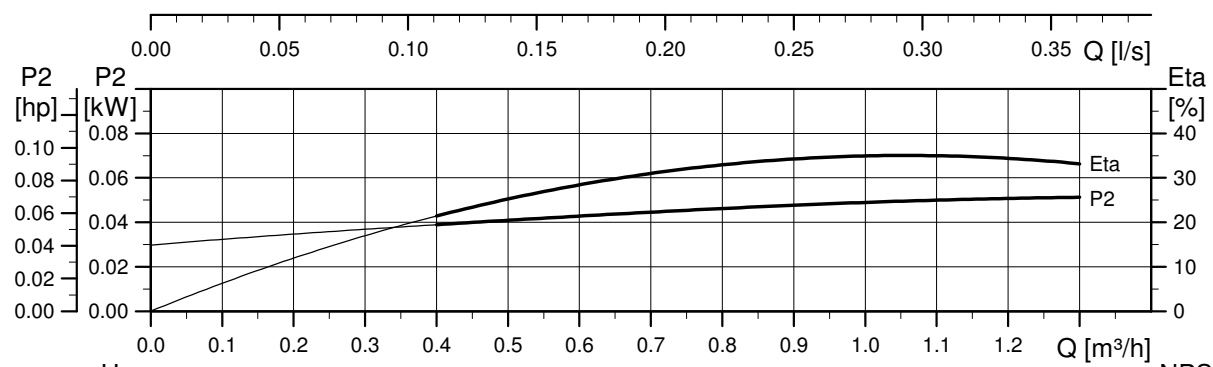
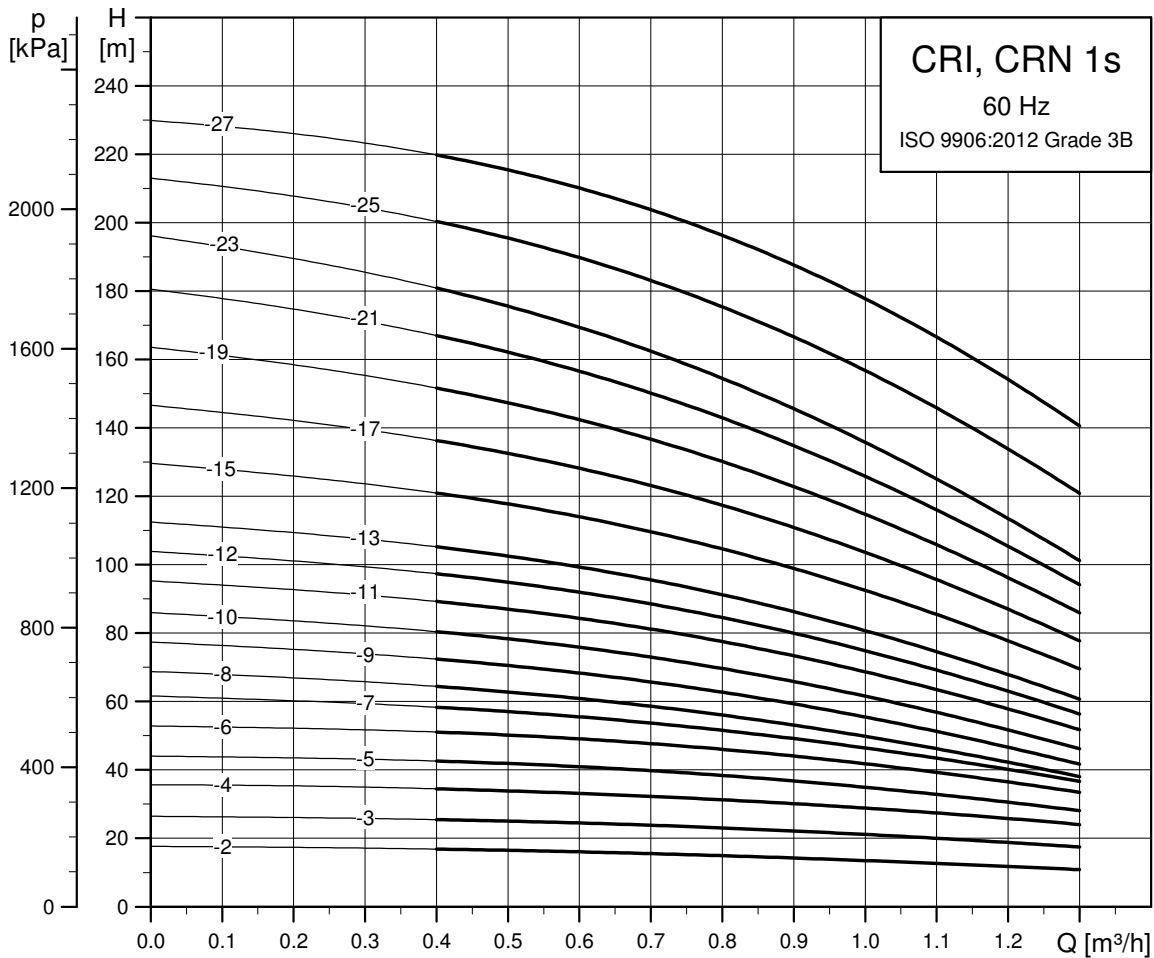

TM02 7423 0918

Dimensional sketch

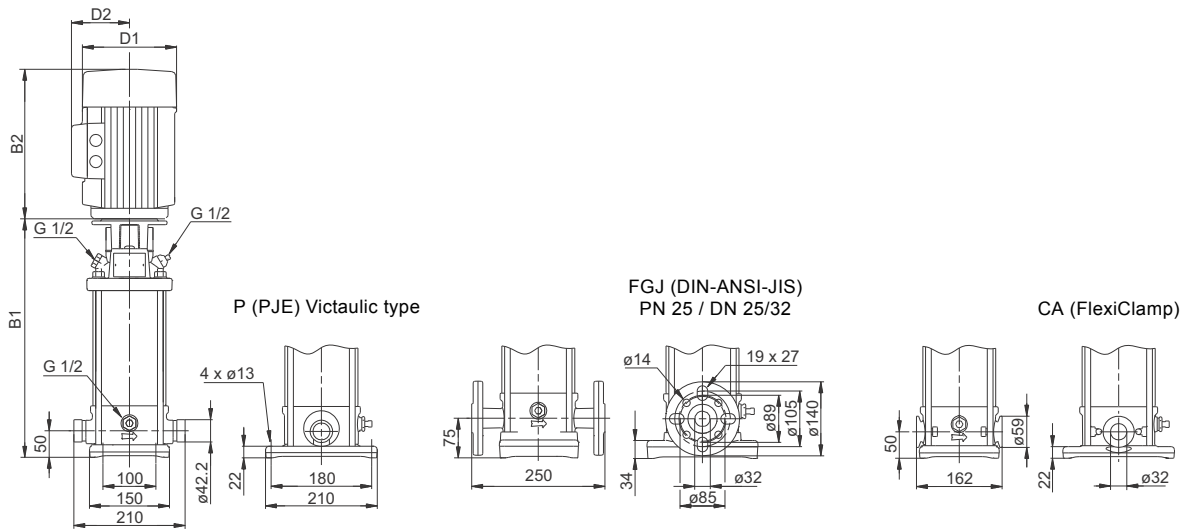

TM06 9592 2517

Dimensions and weights

Pump type	Motor P ₂ [kW]	Dimension [mm]						Net weight [kg]	
		PJE/CA		DIN flange		D1	D2	PJE/CA	DIN flange
		B1	B1+B2	B1	B1+B2				
CRI/CRN 1s-2	0.37	257	448	282	473	141	109	16	20
CRI/CRN 1s-3	0.37	257	448	282	473	141	109	16	21
CRI/CRN 1s-4	0.37	275	466	300	491	141	109	17	21
CRI/CRN 1s-5	0.37	293	484	318	509	141	109	17	21
CRI/CRN 1s-6	0.37	311	502	336	527	141	109	18	22
CRI/CRN 1s-7	0.37	329	520	354	545	141	109	18	22
CRI/CRN 1s-8	0.55	347	538	372	563	141	109	19	23
CRI/CRN 1s-9	0.55	365	556	390	581	141	109	19	24
CRI/CRN 1s-10	0.55	383	574	408	599	141	109	20	24
CRI/CRN 1s-11	0.75	407	638	432	663	141	109	22	27
CRI/CRN 1s-12	0.75	425	656	450	681	141	109	23	27
CRI/CRN 1s-13	0.75	443	674	468	699	141	109	23	27
CRI/CRN 1s-15	1.1	479	730	504	755	141	109	26	30
CRI/CRN 1s-17	1.1	515	766	540	791	141	109	27	31
CRI/CRN 1s-19	1.1	551	802	576	827	141	109	28	32
CRI/CRN 1s-21	1.1	587	838	612	863	141	109	29	33
CRI/CRN 1s-23	1.5	639	920	664	945	178	110	36	40
CRI/CRN 1s-25	1.5	675	956	700	981	178	110	37	41
CRI/CRN 1s-27	1.5	711	992	736	1017	178	110	37	42

CR 1

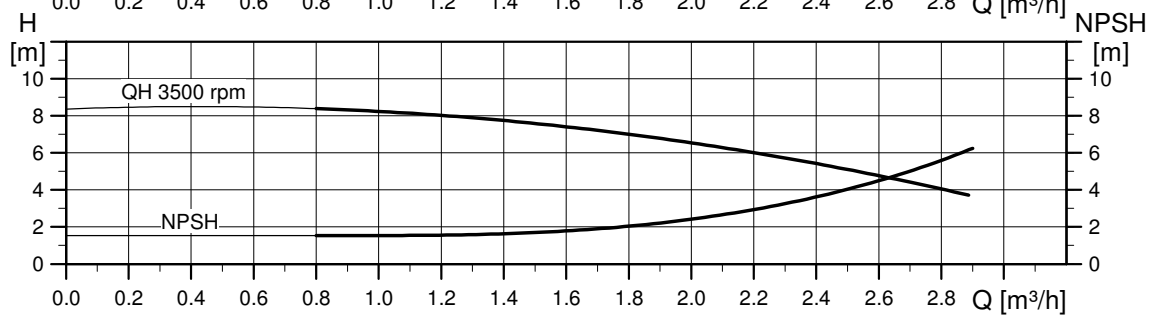
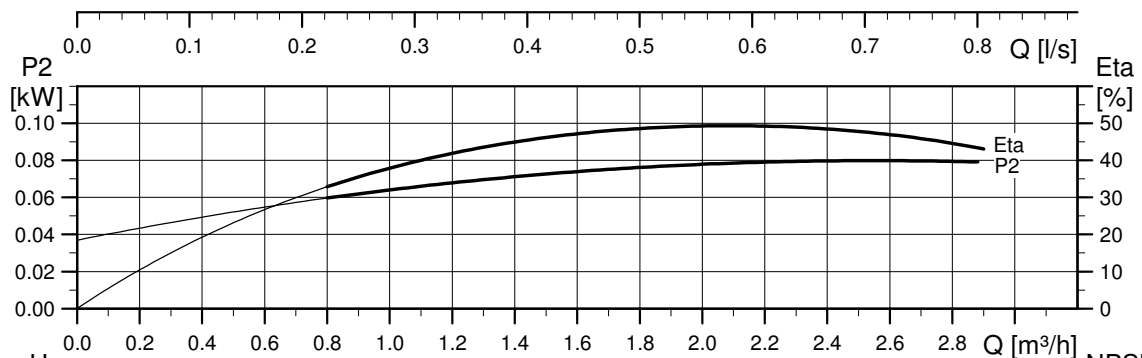
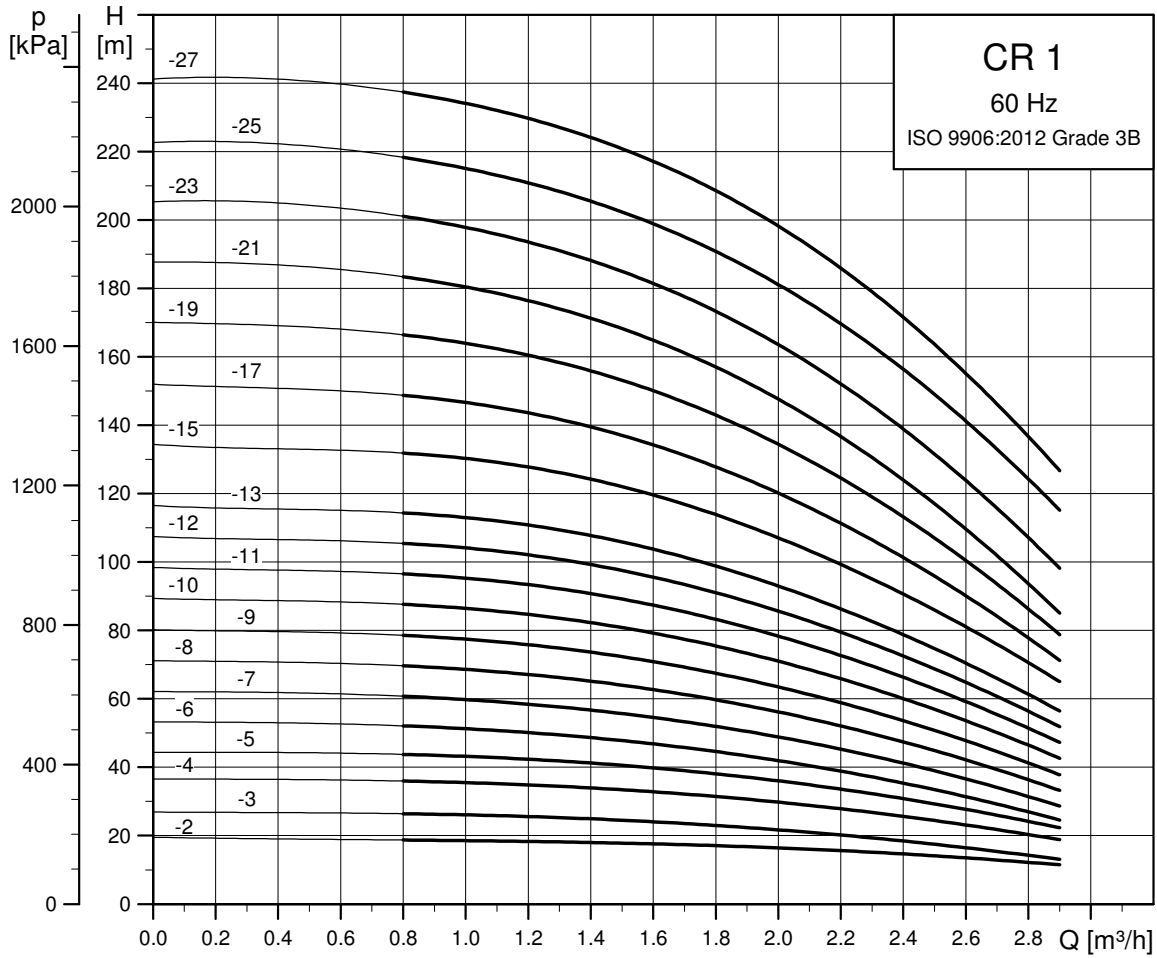

TM02 7310 0918

Dimensional sketch

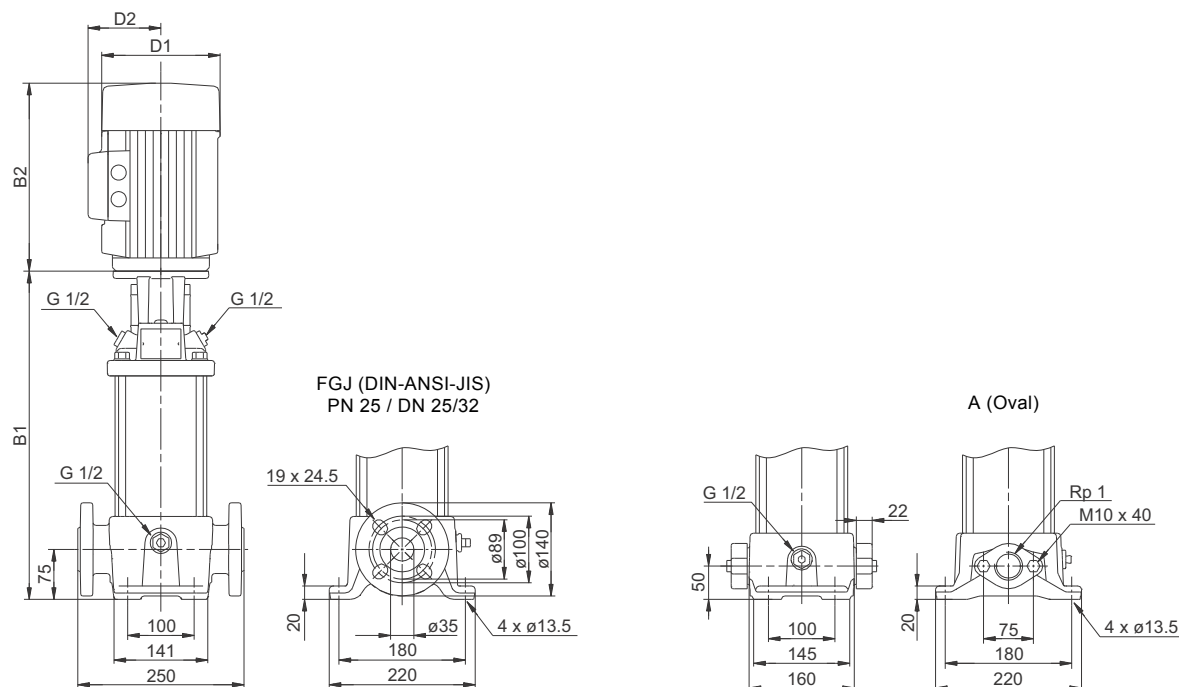

TM06 9591 2517

Dimensions and weights

Pump type	Motor P ₂ [kW]	CR							
		Dimension [mm]						Net weight [kg]	
		Oval flange		DIN flange		D1	D2	Oval flange	DIN flange
B1	B1+B2	B1	B1+B2						
CR 1-2	0.37	254	445	279	470	141	109	18	23
CR 1-3	0.37	254	445	279	470	141	109	18	23
CR 1-4	0.37	272	463	297	488	141	109	19	23
CR 1-5	0.55	290	481	315	506	141	109	20	24
CR 1-6	0.55	308	499	333	524	141	109	20	25
CR 1-7	0.75	332	563	357	588	141	109	22	27
CR 1-8	0.75	350	581	375	606	141	109	23	27
CR 1-9	0.75	368	599	393	624	141	109	23	28
CR 1-10	1.1	386	637	411	662	141	109	26	30
CR 1-11	1.1	404	655	429	680	141	109	26	31
CR 1-12	1.1	422	673	447	698	141	109	27	31
CR 1-13	1.1	440	691	465	716	141	109	27	32
CR 1-15	1.5	492	773	517	798	178	110	35	39
CR 1-17	1.5	528	809	553	834	178	110	36	40
CR 1-19	2.2	-	-	589	910	178	110	-	42
CR 1-21	2.2	-	-	625	946	178	110	-	42
CR 1-23	2.2	-	-	661	982	178	110	-	43
CR 1-25	2.2	-	-	697	1018	178	110	-	44
CR 1-27	3	-	-	737	1072	198	120	-	51

CRI, CRN 1

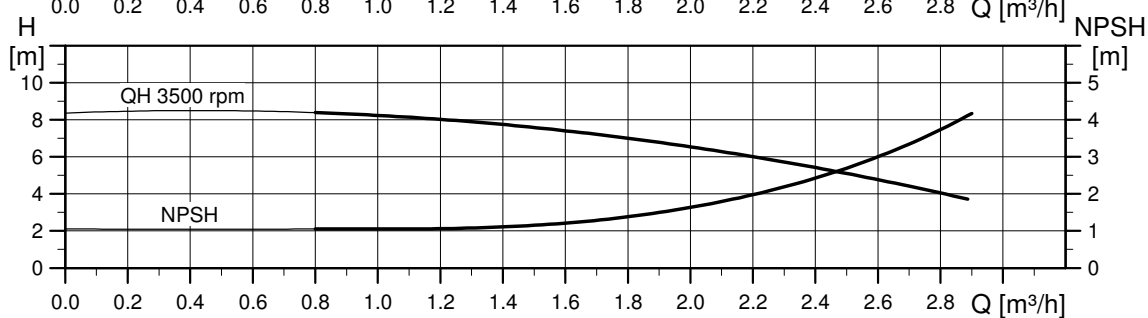
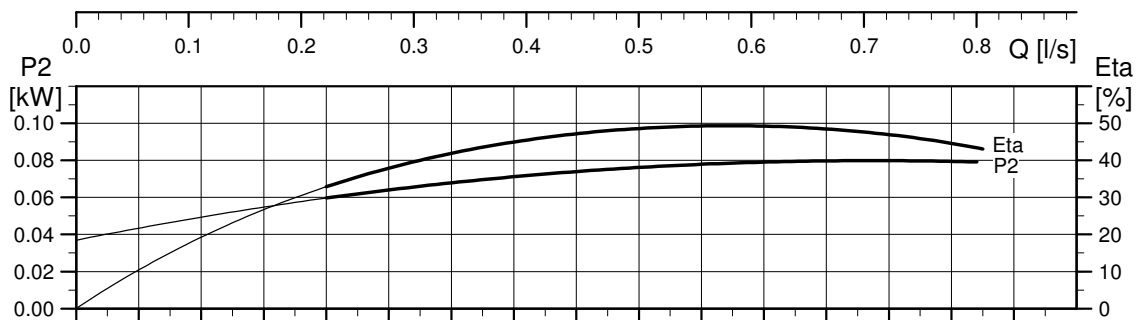
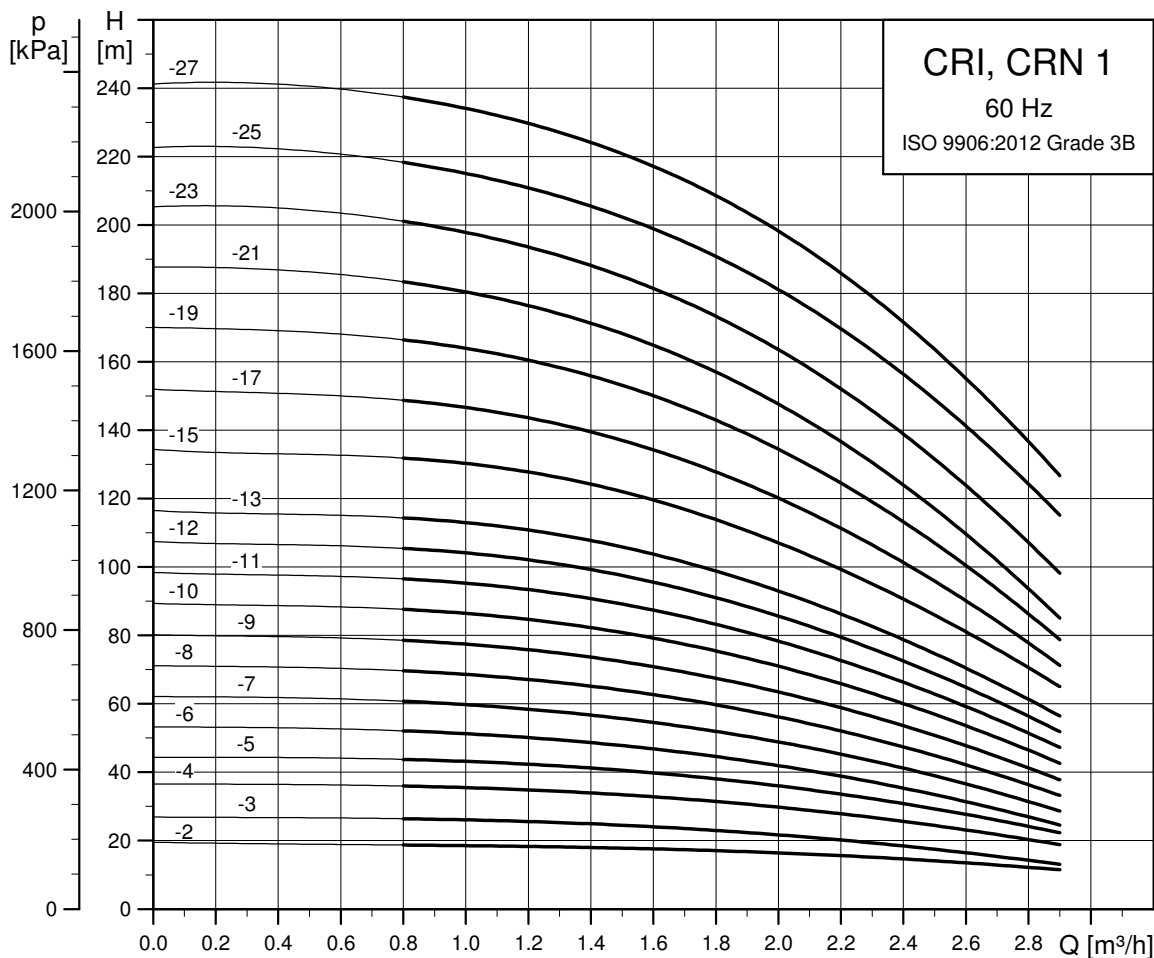

TM02 7311 0918

Dimensional sketch

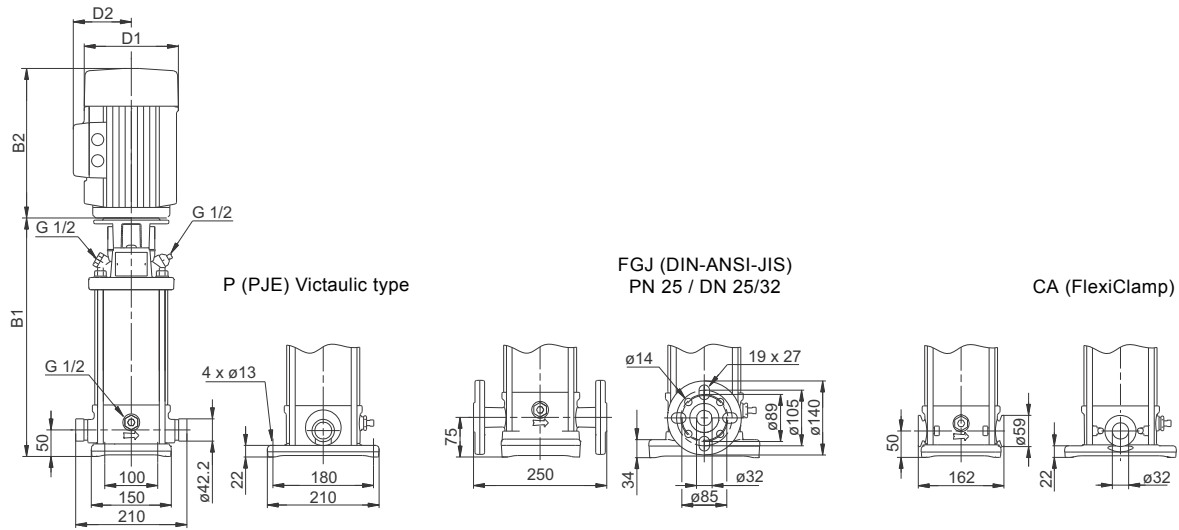

Dimensions and weights

Pump type	Motor P ₂ [kW]	CRI/CRN							
		Dimension [mm]				Net weight [kg]			
		PJE/CA		DIN flange		D1	D2	PJE/CA	DIN flange
B1	B1+B2	B1	B1+B2						
CRI/CRN 1-2	0.37	257	448	282	473	141	109	16	20
CRI/CRN 1-3	0.37	257	448	282	473	141	109	16	21
CRI/CRN 1-4	0.37	275	466	300	491	141	109	17	21
CRI/CRN 1-5	0.55	293	484	318	509	141	109	18	22
CRI/CRN 1-6	0.55	311	502	336	527	141	109	18	22
CRI/CRN 1-7	0.75	335	566	360	591	141	109	21	25
CRI/CRN 1-8	0.75	353	584	378	609	141	109	21	26
CRI/CRN 1-9	0.75	371	602	396	627	141	109	22	26
CRI/CRN 1-10	1.1	389	640	414	665	141	109	24	29
CRI/CRN 1-11	1.1	407	658	432	683	141	109	25	29
CRI/CRN 1-12	1.1	425	676	450	701	141	109	25	29
CRI/CRN 1-13	1.1	443	694	468	719	141	109	26	30
CRI/CRN 1-15	1.5	495	776	520	801	178	110	33	37
CRI/CRN 1-17	1.5	531	812	556	837	178	110	34	38
CRI/CRN 1-19	2.2	567	888	592	913	178	110	35	39
CRI/CRN 1-21	2.2	603	924	628	949	178	110	36	40
CRI/CRN 1-23	2.2	639	960	664	985	178	110	37	41
CRI/CRN 1-25	2.2	675	996	700	1021	178	110	37	42
CRI/CRN 1-27	3	716	1051	741	1076	198	120	45	49

TM06 9592 25 17

CR 3

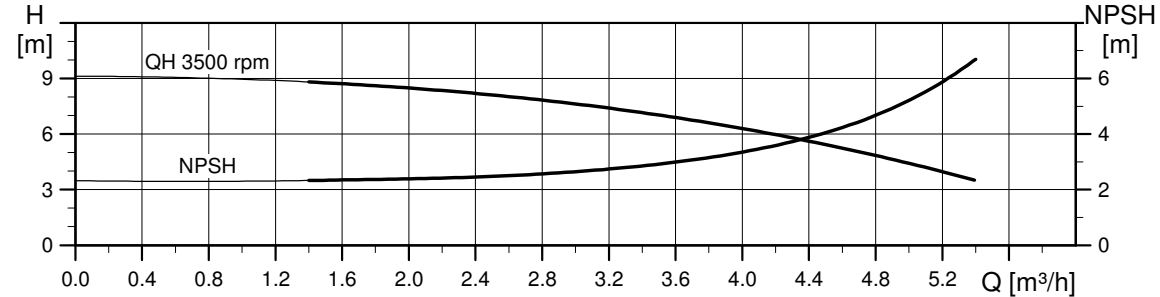
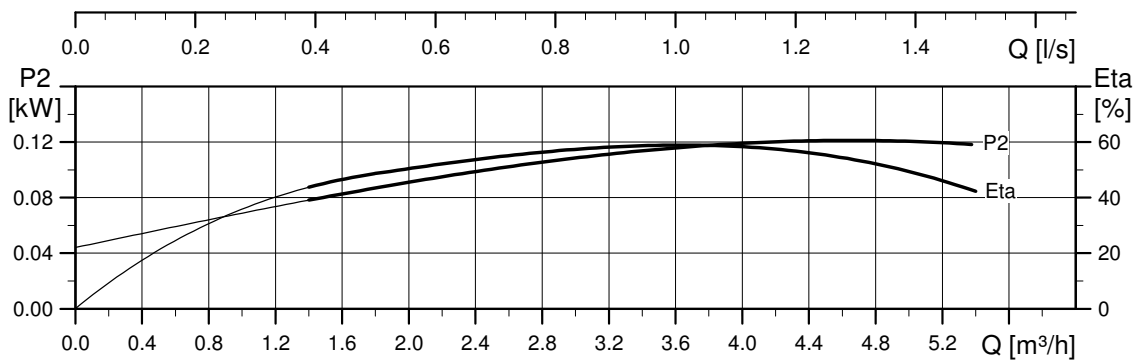
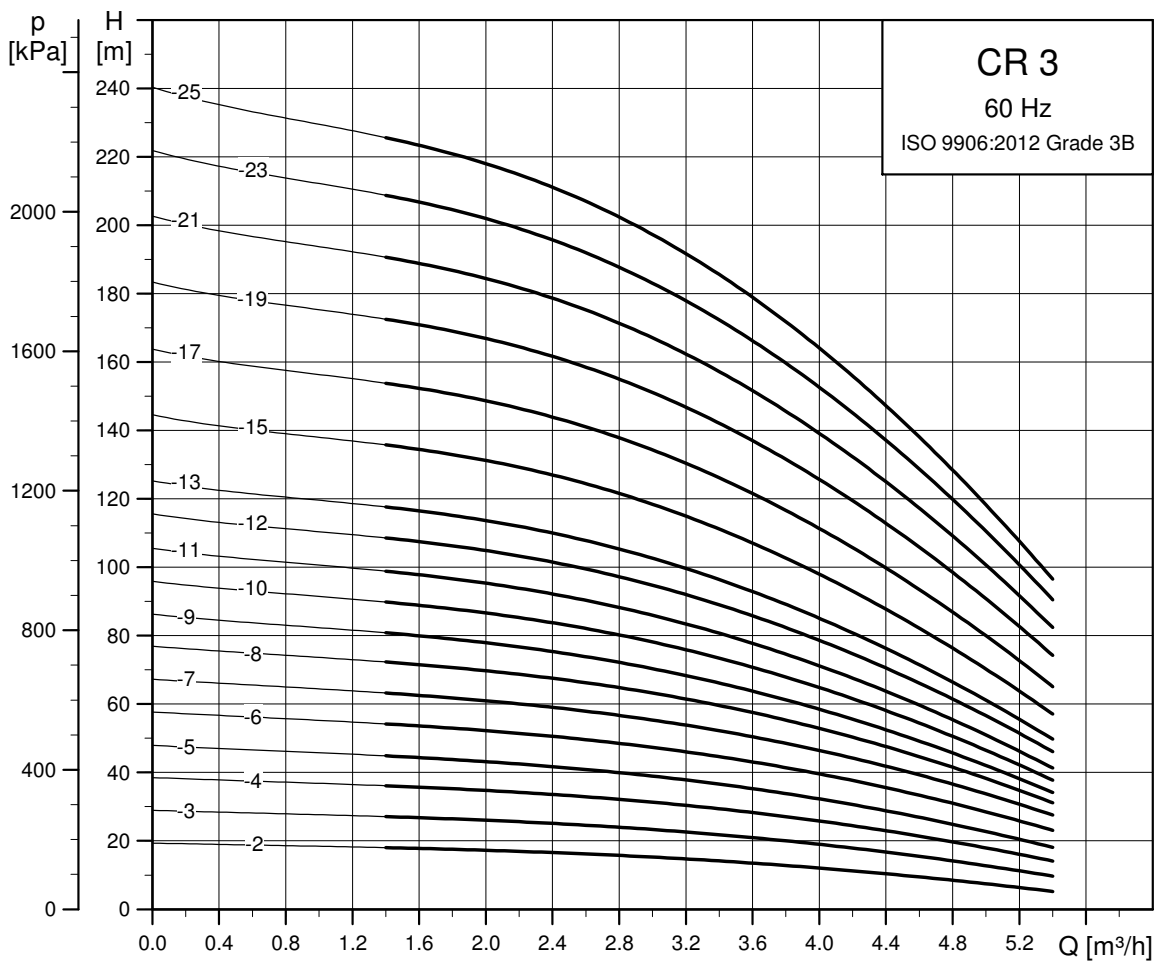

TM02 7312 0918

Dimensional sketch

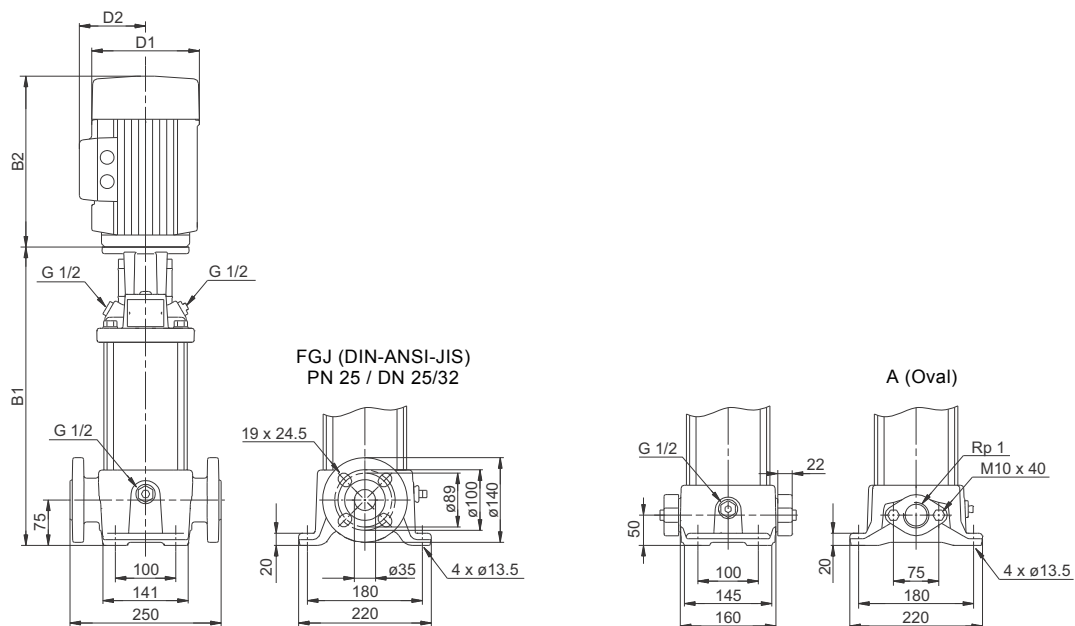

TM06 9591 2517

Dimensions and weights

Pump type	Motor P ₂ [kW]	CR							
		Dimension [mm]						Net weight [kg]	
		Oval flange		DIN flange		D1	D2	Oval flange	DIN flange
B1	B1+B2	B1	B1+B2						
CR 3-2	0.37	254	445	279	470	141	109	18	23
CR 3-3	0.55	254	445	279	470	141	109	19	24
CR 3-4	0.55	272	463	297	488	141	109	19	24
CR 3-5	0.75	296	527	321	552	141	109	22	26
CR 3-6	1.1	314	565	339	590	141	109	24	29
CR 3-7	1.1	332	583	357	608	141	109	24	29
CR 3-8	1.1	350	601	375	626	141	109	25	30
CR 3-9	1.5	384	665	409	690	178	110	32	37
CR 3-10	1.5	402	683	427	708	178	110	33	37
CR 3-11	1.5	420	701	445	726	178	110	33	38
CR 3-12	2.2	438	759	463	784	178	110	34	39
CR 3-13	2.2	456	777	481	802	178	110	34	39
CR 3-15	2.2	492	813	517	838	178	110	35	40
CR 3-17	2.2	528	849	553	874	178	110	36	41
CR 3-19	3	-	-	593	928	198	120	-	48
CR 3-21	3	-	-	629	964	198	120	-	49
CR 3-23	3	-	-	665	1000	198	120	-	49
CR 3-25	4	-	-	701	1073	220	134	-	59

CRI, CRN 3

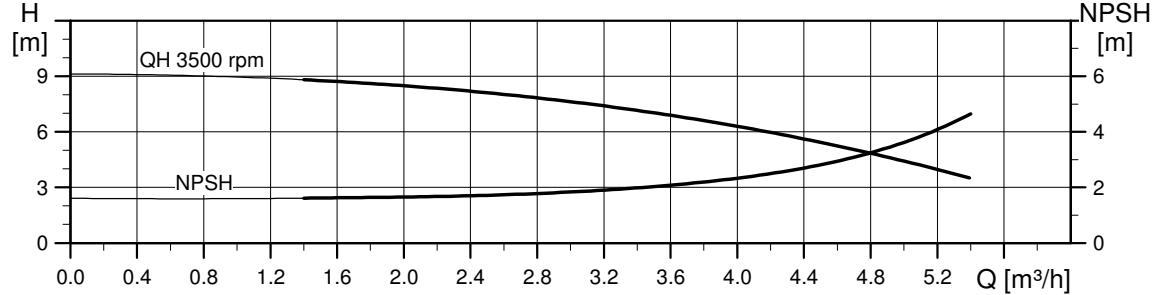
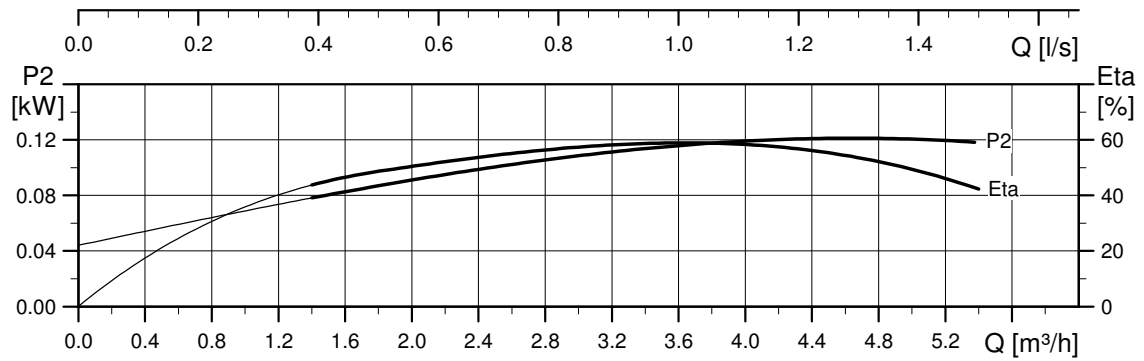
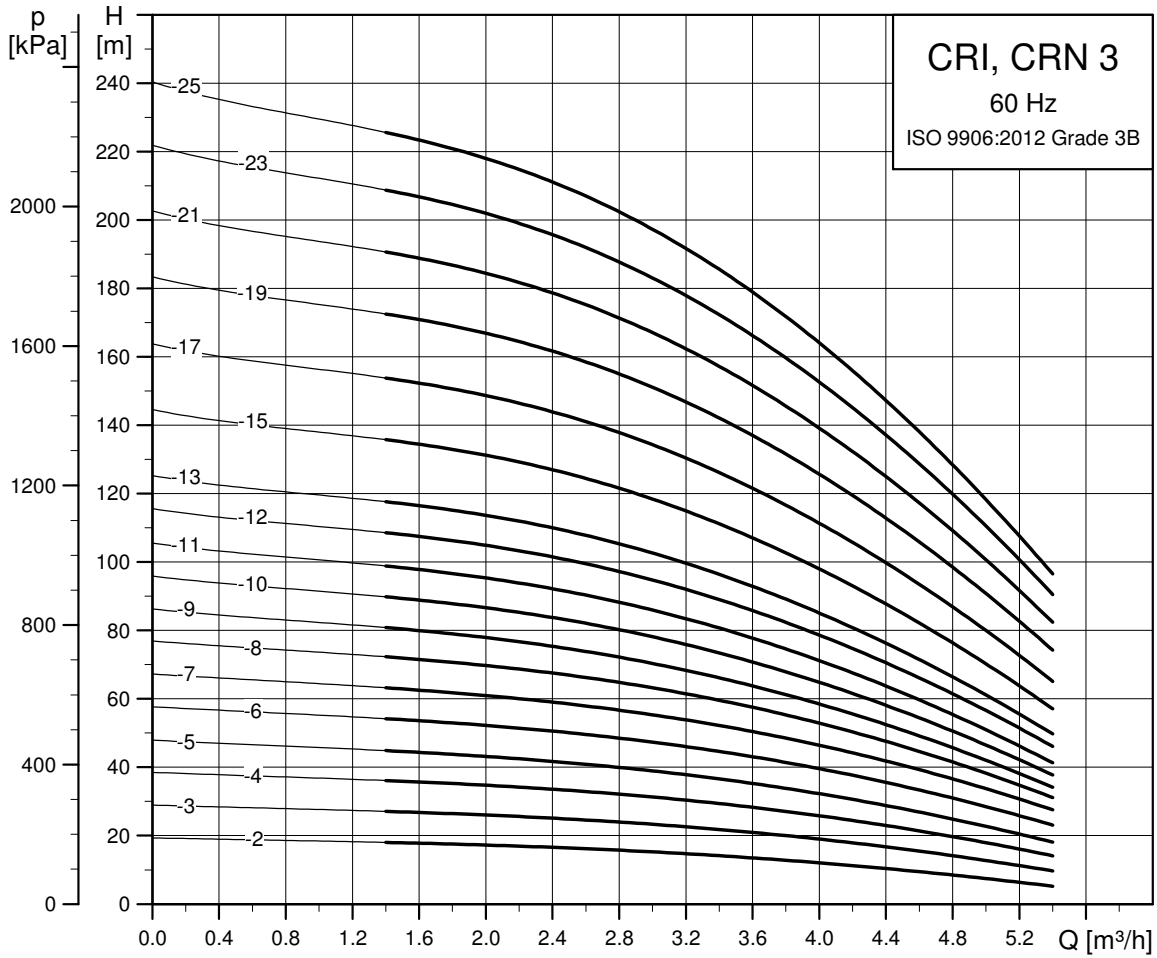

TM02.7313.0918

Dimensional sketch

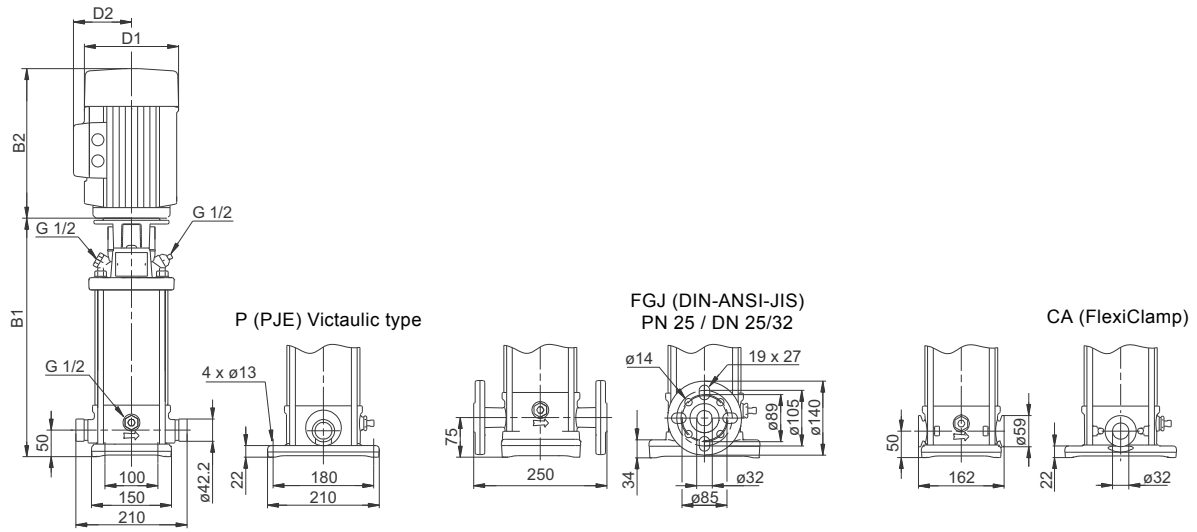

TM06 9592 2517

Dimensions and weights

Pump type	Motor P ₂ [kW]	CRI/CRN							
		Dimension [mm]				Net weight [kg]			
		PJE/CA		DIN flange		D1	D2	PJE/CA	DIN flange
B1	B1+B2	B1	B1+B2						
CRI/CRN 3-2	0.37	257	448	282	473	141	109	16	20
CRI/CRN 3-3	0.55	257	448	282	473	141	109	17	21
CRI/CRN 3-4	0.55	275	466	300	491	141	109	17	22
CRI/CRN 3-5	0.75	299	530	324	555	141	109	20	24
CRI/CRN 3-6	1.1	317	568	342	593	141	109	23	27
CRI/CRN 3-7	1.1	335	586	360	611	141	109	23	27
CRI/CRN 3-8	1.1	353	604	378	629	141	109	24	28
CRI/CRN 3-9	1.5	387	668	412	693	178	110	30	35
CRI/CRN 3-10	1.5	405	686	430	711	178	110	31	35
CRI/CRN 3-11	1.5	423	704	448	729	178	110	31	35
CRI/CRN 3-12	2.2	441	762	466	787	178	110	32	36
CRI/CRN 3-13	2.2	459	780	484	805	178	110	33	37
CRI/CRN 3-15	2.2	495	816	520	841	178	110	33	38
CRI/CRN 3-17	2.2	531	852	556	877	178	110	34	38
CRI/CRN 3-19	3	572	907	597	932	198	120	41	46
CRI/CRN 3-21	3	608	943	633	968	198	120	42	46
CRI/CRN 3-23	3	644	979	669	1004	198	120	43	47
CRI/CRN 3-25	4	680	1052	705	1077	220	134	53	57

CR 5

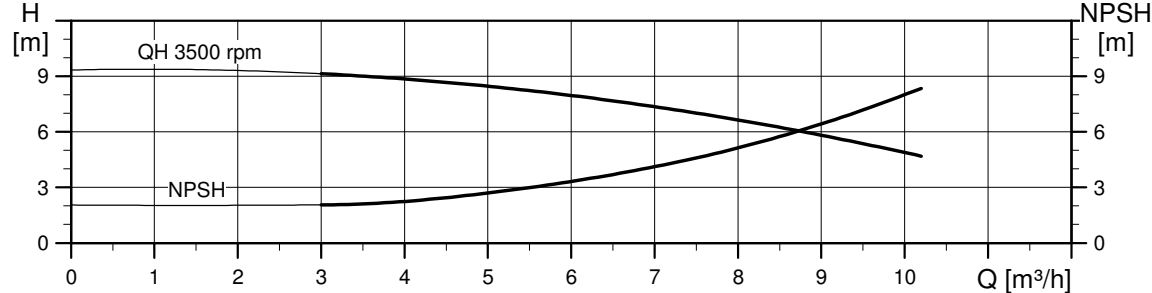
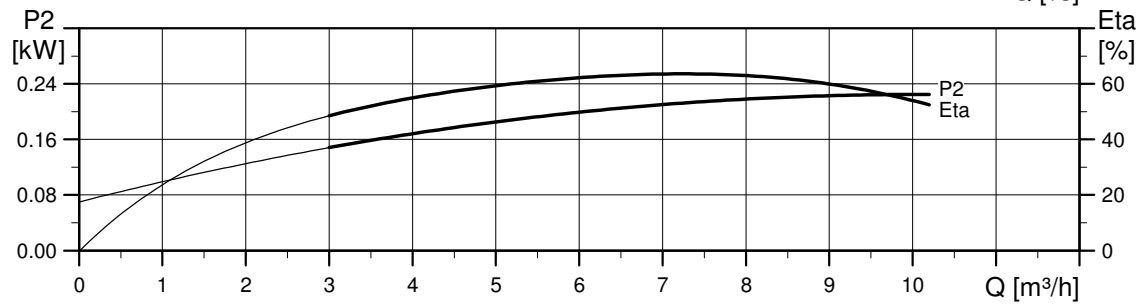
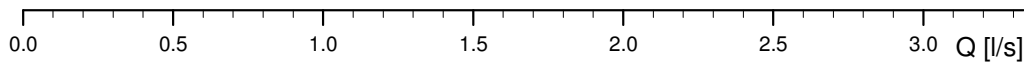
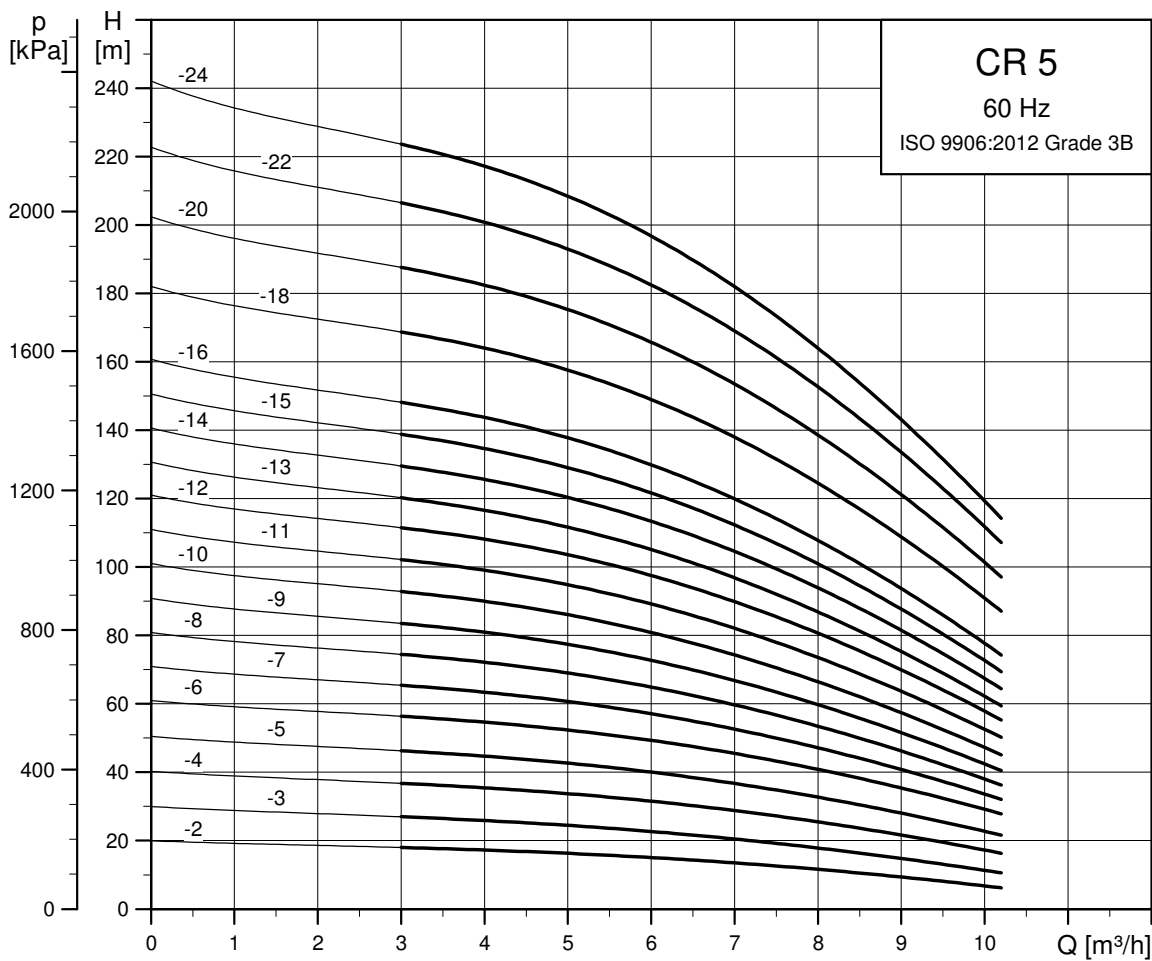

TM02 7314 0918

Dimensional sketch

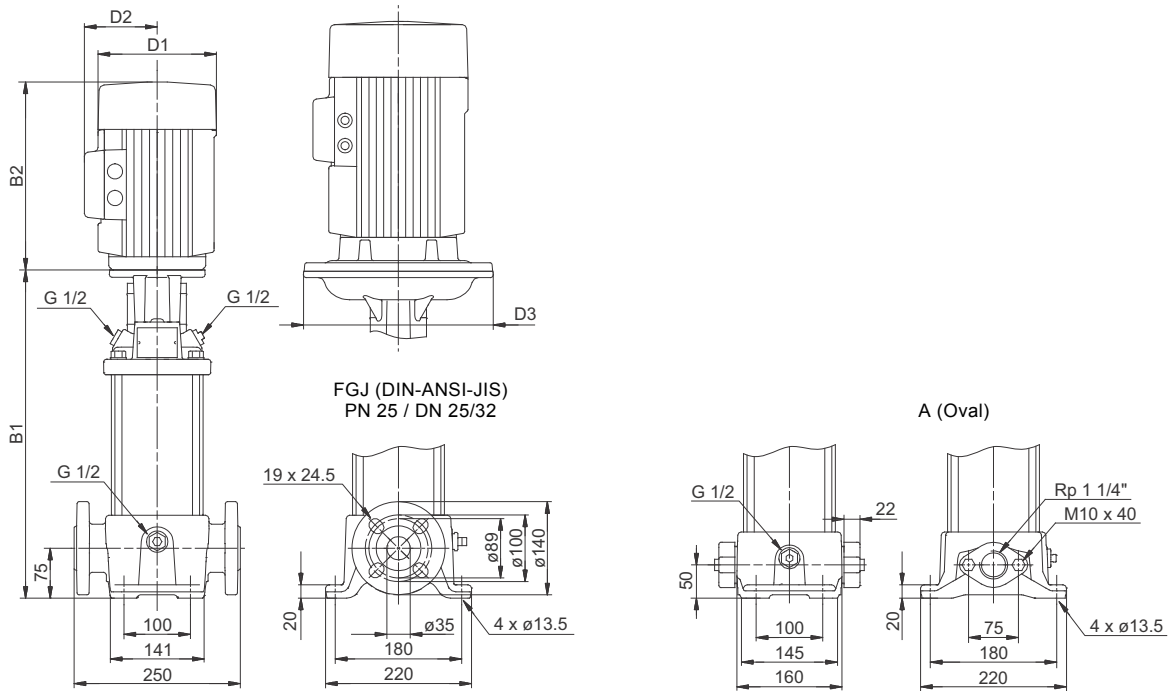

TM06 9593 2517

Dimensions and weights

Pump type	Motor P ₂ [kW]	CR								
		Dimension [mm]						Net weight [kg]		
		Oval flange		DIN flange		D1	D2	D3	Oval flange	DIN flange
B1	B1+B2	B1	B1+B2							
CR 5-2	0.55	254	445	279	470	141	109	-	19	23
CR 5-3	1.1	287	538	312	563	141	109	-	23	28
CR 5-4	1.1	314	565	339	590	141	109	-	24	29
CR 5-5	1.5	357	638	382	663	178	110	-	32	36
CR 5-6	2.2	384	705	409	730	178	110	-	33	37
CR 5-7	2.2	411	732	436	757	178	110	-	33	38
CR 5-8	2.2	438	759	463	784	178	110	-	34	38
CR 5-9	2.2	465	786	490	811	178	110	-	34	39
CR 5-10	3	496	831	521	856	198	120	-	41	46
CR 5-11	3	523	858	548	883	198	120	-	42	46
CR 5-12	3	550	885	575	910	198	120	-	42	47
CR 5-13	4	577	949	602	974	220	134	-	52	56
CR 5-14	4	604	976	629	1001	220	134	-	53	57
CR 5-15	4	631	1003	656	1028	220	134	-	53	58
CR 5-16	4	658	1030	683	1055	220	134	-	54	58
CR 5-18	5.5	-	-	767	1158	220	134	300	-	74
CR 5-20	5.5	-	-	821	1212	220	134	300	-	75
CR 5-22	5.5	-	-	875	1266	220	134	300	-	76
CR 5-24	7.5	-	-	929	1308	260	159	300	-	88

CRI, CRN 5

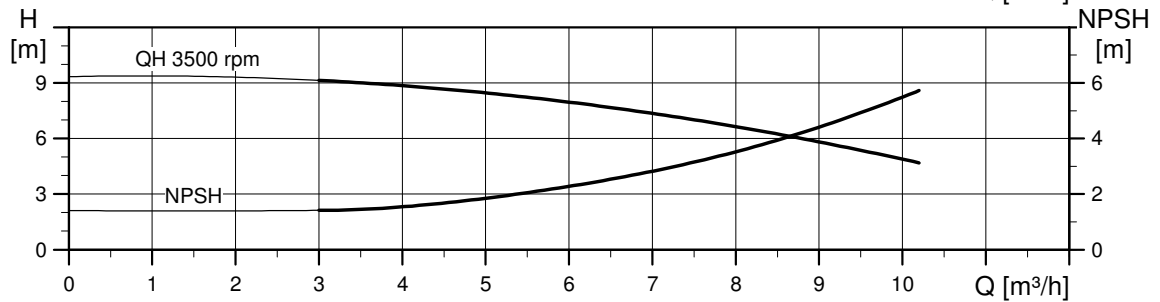
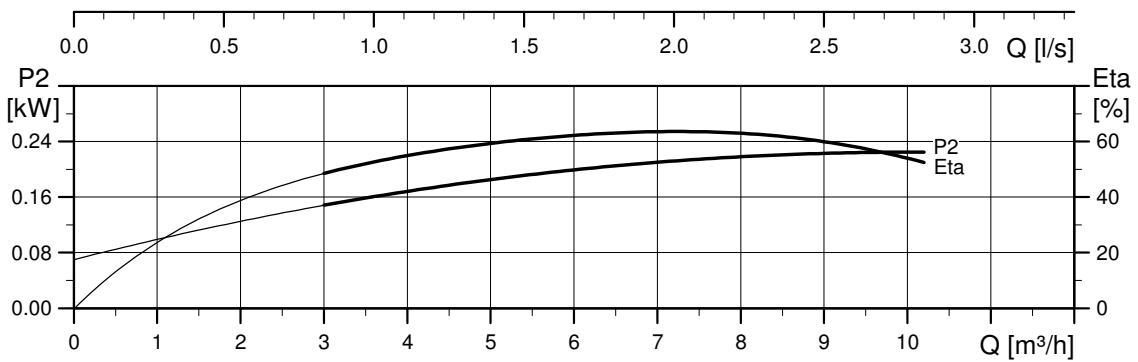
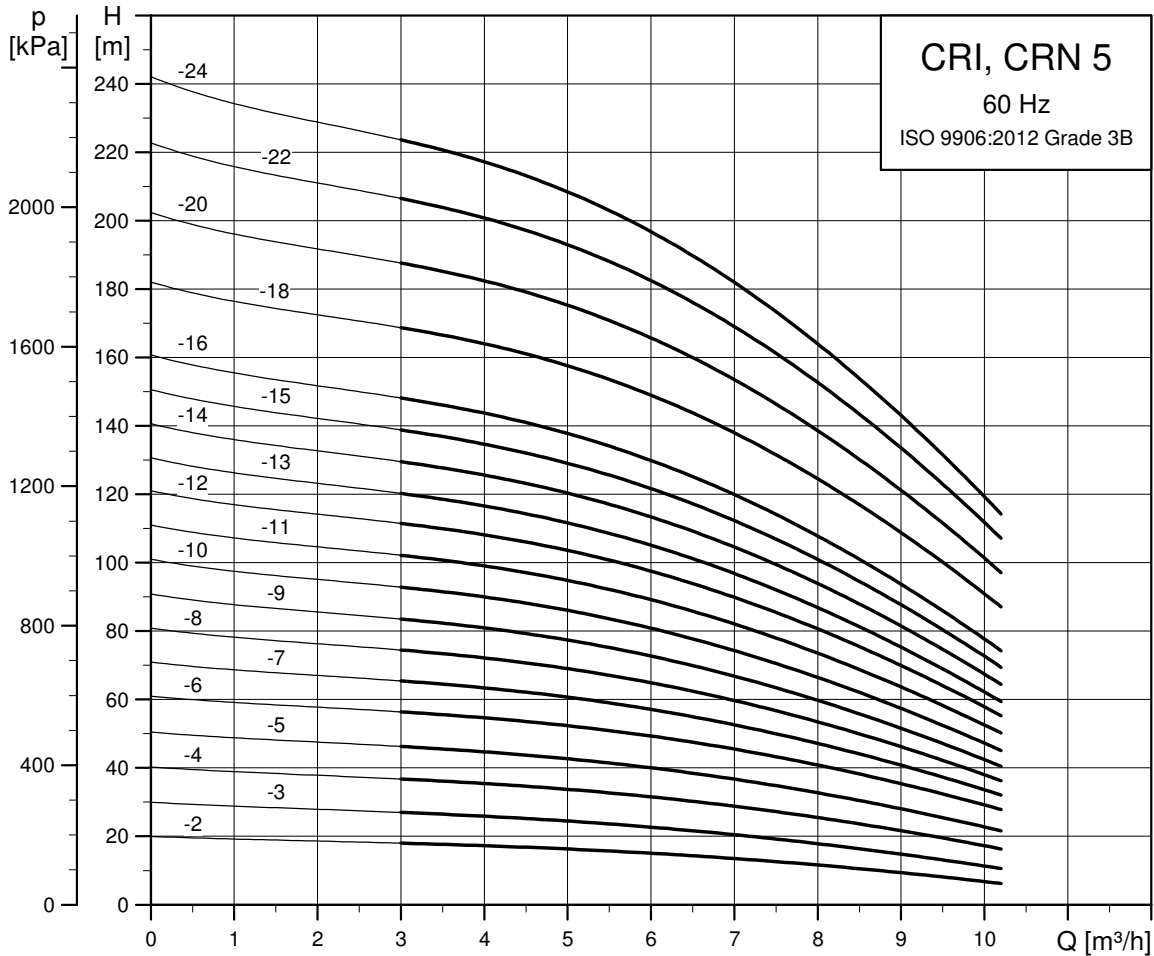

TM02 7315 0918

Dimensional sketch

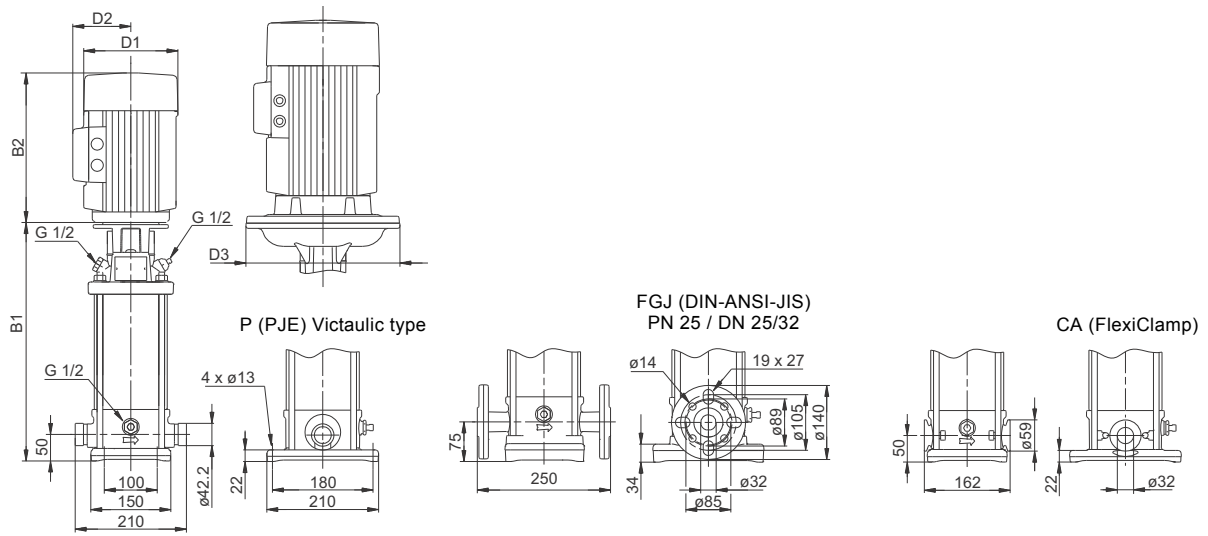

TM/06 9594 2517

Dimensions and weights

Pump type	Motor P ₂ [kW]	CRI/CRN								
		Dimension [mm]							Net weight [kg]	
		PJE/CA		DIN flange		D1	D2	D3	PJE/CA	DIN flange
		B1	B1+B2	B1	B1+B2					
CRI/CRN 5-2	0.55	257	448	282	473	141	109	-	17	21
CRI/CRN 5-3	1.1	290	541	315	566	141	109	-	22	26
CRI/CRN 5-4	1.1	317	568	342	593	141	109	-	23	27
CRI/CRN 5-5	1.5	360	641	385	666	178	110	-	30	34
CRI/CRN 5-6	2.2	387	708	412	733	178	110	-	31	35
CRI/CRN 5-7	2.2	414	735	439	760	178	110	-	31	35
CRI/CRN 5-8	2.2	441	762	466	787	178	110	-	32	36
CRI/CRN 5-9	2.2	468	789	493	814	178	110	-	32	37
CRI/CRN 5-10	3	500	835	525	860	198	120	-	39	44
CRI/CRN 5-11	3	527	862	552	887	198	120	-	40	44
CRI/CRN 5-12	3	554	889	579	914	198	120	-	41	45
CRI/CRN 5-13	4	581	953	606	978	220	134	-	50	54
CRI/CRN 5-14	4	608	980	633	1005	220	134	-	51	55
CRI/CRN 5-15	4	635	1007	660	1032	220	134	-	51	55
CRI/CRN 5-16	4	662	1034	687	1059	220	134	-	52	56
CRI/CRN 5-18	5.5	745	1136	770	1161	220	134	300	67	71
CRI/CRN 5-20	5.5	799	1190	824	1215	220	134	300	68	72
CRI/CRN 5-22	5.5	853	1244	878	1269	220	134	300	69	73
CRI/CRN 5-24	7.5	907	1286	932	1311	260	159	300	81	85

CR 10

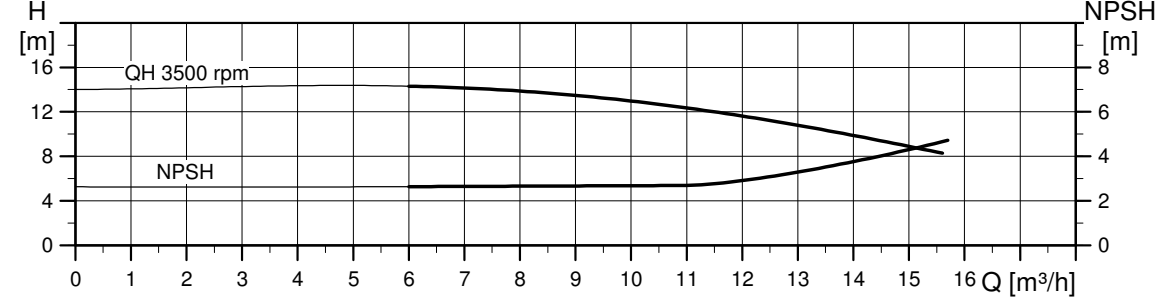
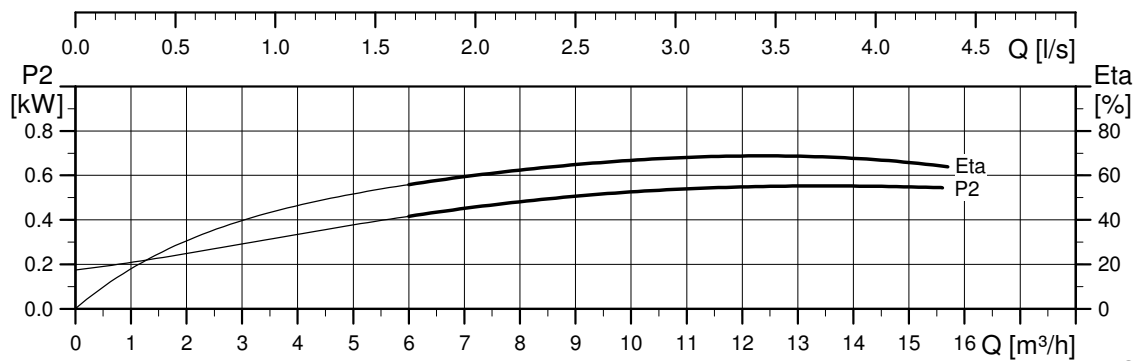
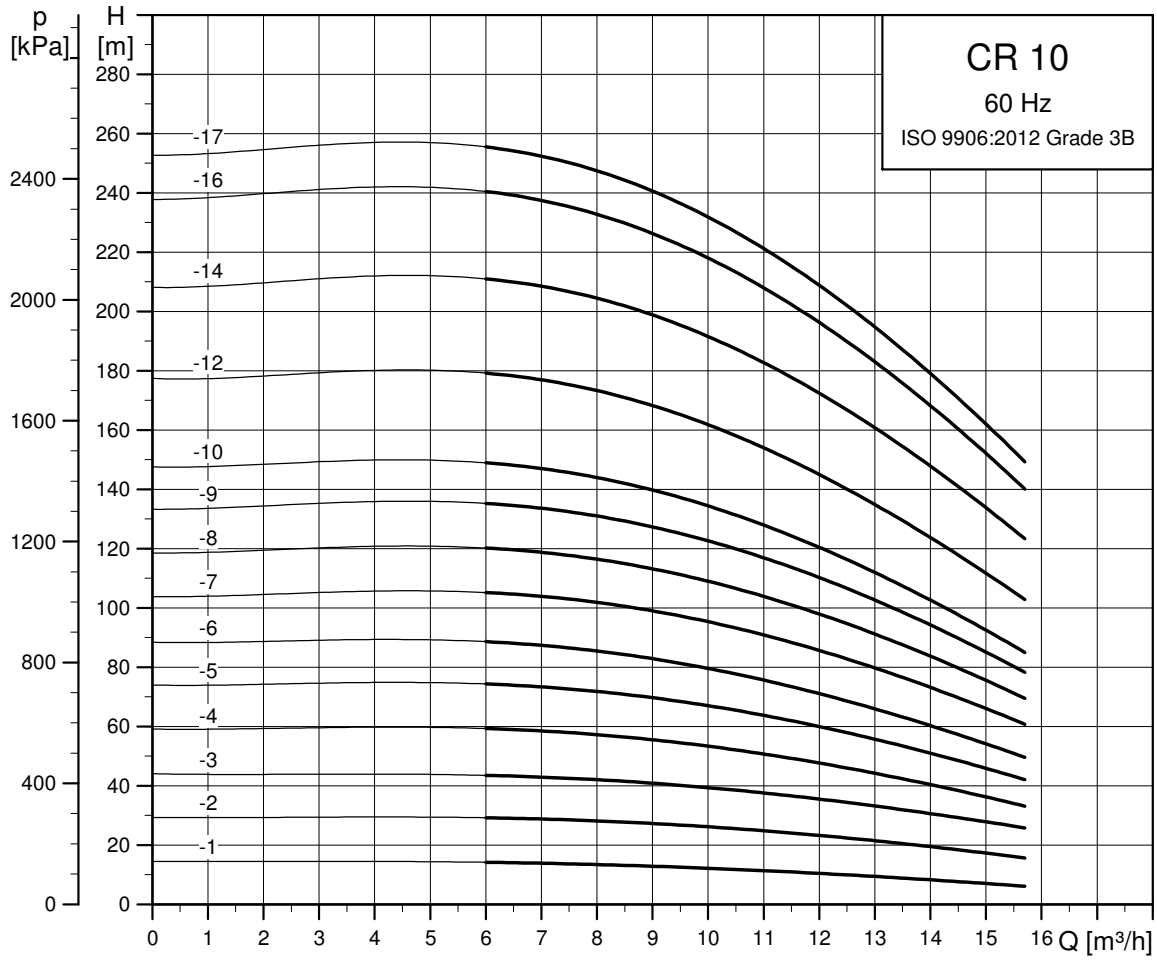

TM02 7316 0918

Dimensional sketch

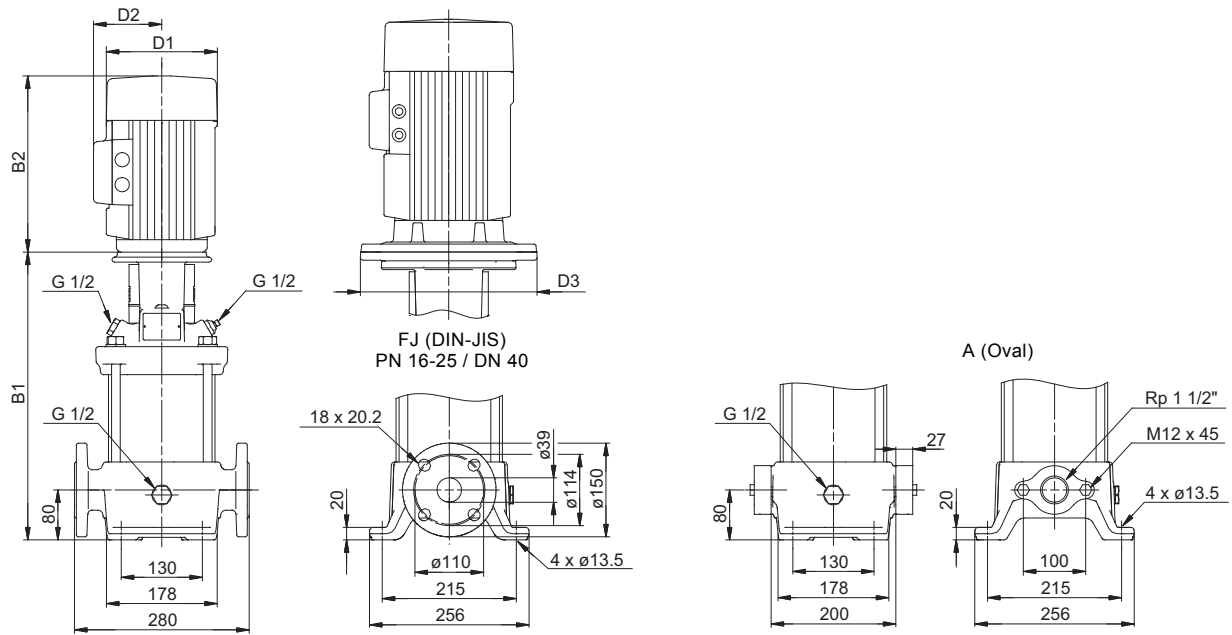

TM06 9595 2517

Dimensions and weights

Pump type	Motor P ₂ [kW]	CR								
		Dimension [mm]						Net weight [kg]		
		Oval flange		DIN flange		D1	D2	D3	Oval flange	DIN flange
		B1	B1+B2	B1	B1+B2					
CR 10-1	0.75	347	578	347	578	141	109	-	33	36
CR 10-2	1.5	363	644	363	644	178	110	-	43	45
CR 10-3	2.2	393	714	393	714	178	110	-	44	47
CR 10-4	3	428	763	428	763	198	120	-	51	54
CR 10-5	3	458	793	458	793	198	120	-	52	55
CR 10-6	4	488	860	488	860	220	134	-	62	65
CR 10-7	5.5	550	941	550	941	220	134	300	84	87
CR 10-8	5.5	580	971	580	971	220	134	300	85	88
CR 10-9	5.5	610	1001	610	1001	220	134	300	86	89
CR 10-10	7.5	640	1019	640	1019	260	159	300	98	100
CR 10-12	7.5	-	-	700	1079	260	159	300	-	103
CR 10-14	11	-	-	837	1308	314	204	350	-	146
CR 10-16	11	-	-	897	1368	314	204	350	-	148
CR 10-17	11	-	-	957	1428	314	204	350	-	150

CRI, CRN 10

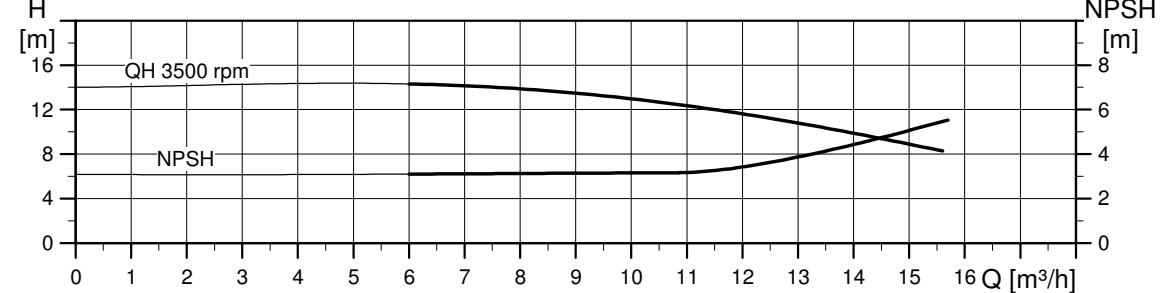
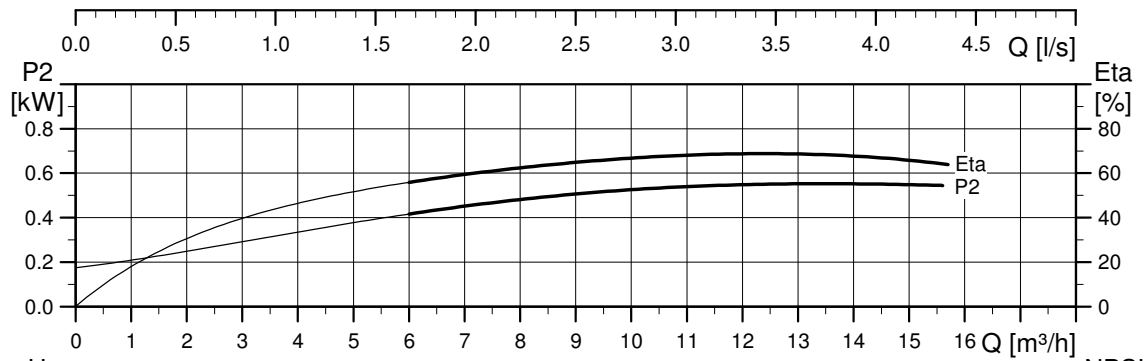
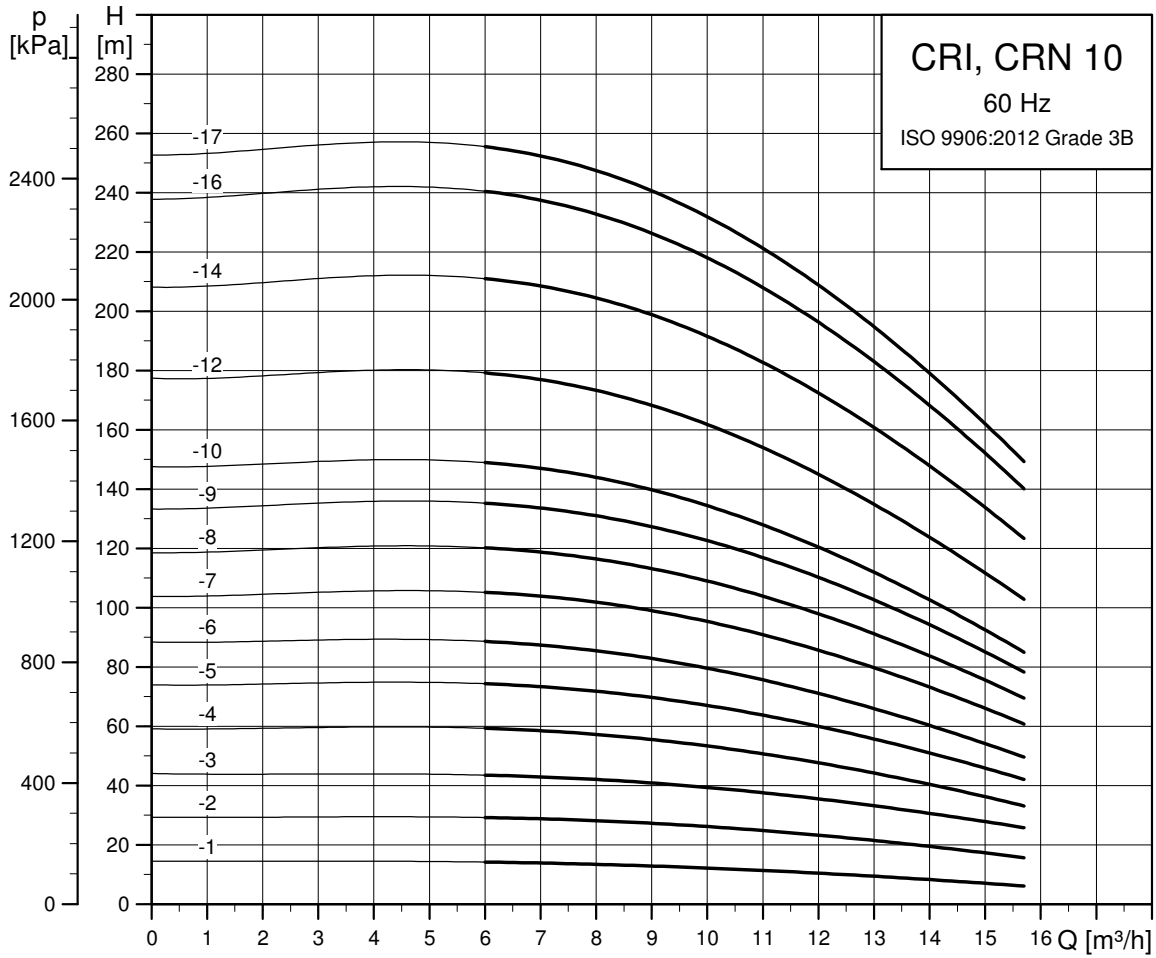

TM02 7317 0918

Dimensional sketch

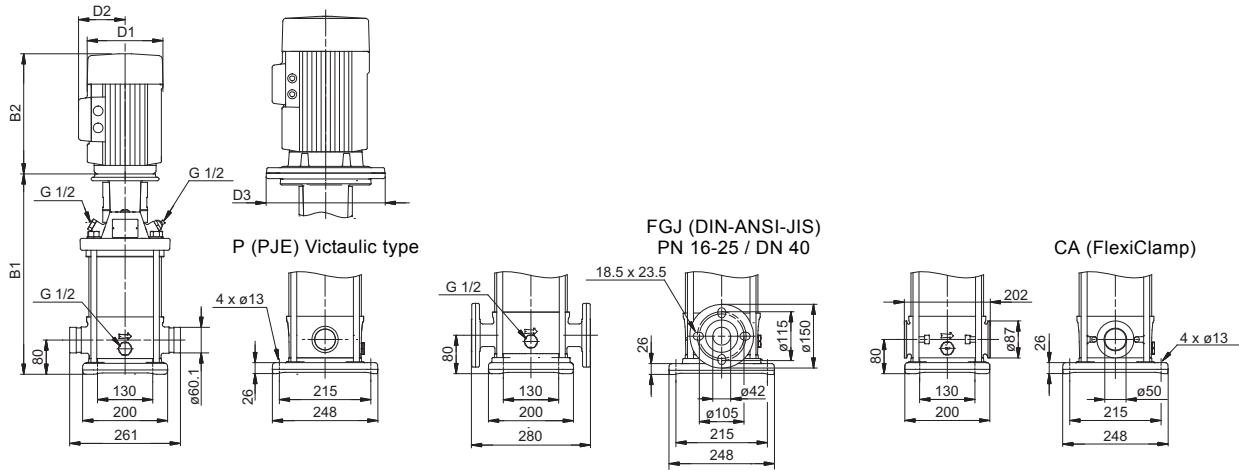

TM06 9596 2517

Dimensions and weights

Pump type	Motor P ₂ [kW]	CRI/CRN									
		Dimension [mm]								Net weight [kg]	
		PJE/CA		DIN flange		D1	D2	D3	PJE/CA	DIN flange	
		B1	B1+B2	B1	B1+B2						
CRI/CRN 10-1	0.75	357	588	357	588	141	109	-	31	34	
CRI/CRN 10-2	1.5	373	654	373	654	178	110	-	40	44	
CRI/CRN 10-3	2.2	403	724	403	724	178	110	-	42	45	
CRI/CRN 10-4	3	438	773	438	773	198	120	-	49	53	
CRI/CRN 10-5	3	468	803	468	803	198	120	-	50	54	
CRI/CRN 10-6	4	498	870	498	870	220	134	-	60	64	
CRI/CRN 10-7	5.5	560	951	560	951	220	134	300	82	85	
CRI/CRN 10-8	5.5	590	981	590	981	220	134	300	83	86	
CRI/CRN 10-9	5.5	620	1011	620	1011	220	134	300	84	87	
CRI/CRN 10-10	7.5	650	1029	650	1029	260	159	300	95	99	
CRI/CRN 10-12	7.5	710	1089	710	1089	260	159	300	98	101	
CRI/CRN 10-14	11	847	1318	847	1318	314	204	350	140	144	
CRI/CRN 10-16	11	907	1378	907	1378	314	204	350	143	146	
CRI/CRN 10-17	11	967	1438	967	1438	314	204	350	145	148	

CR 15

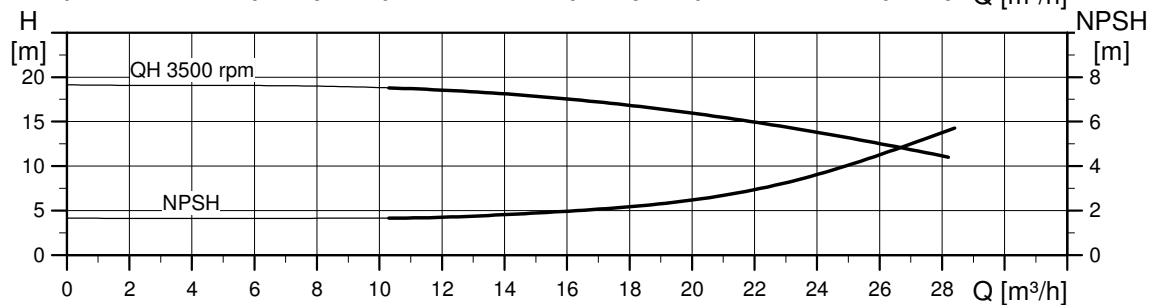
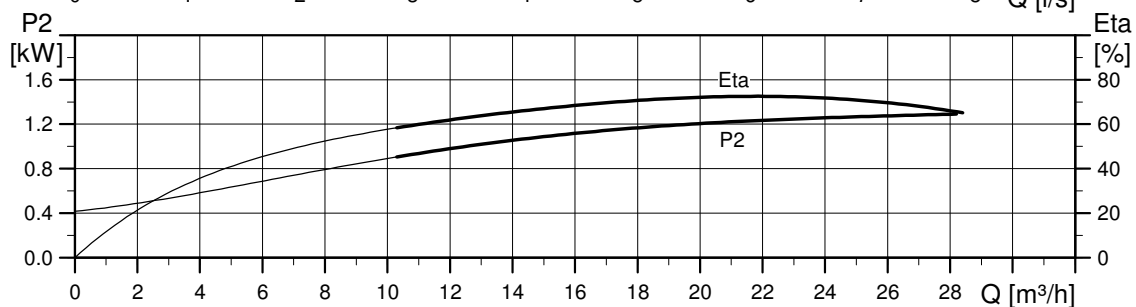
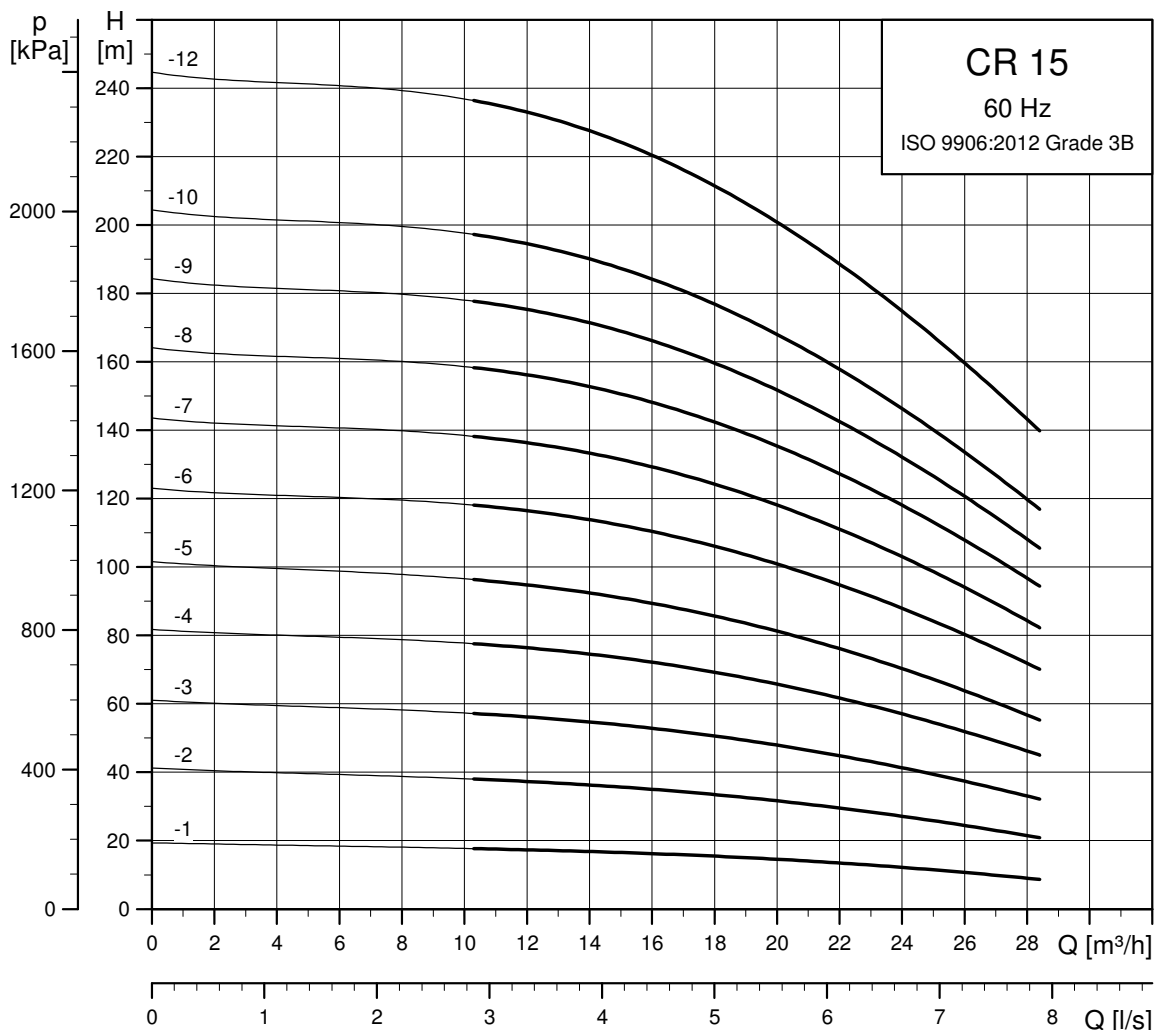

TM02 7318 0918

Dimensional sketch

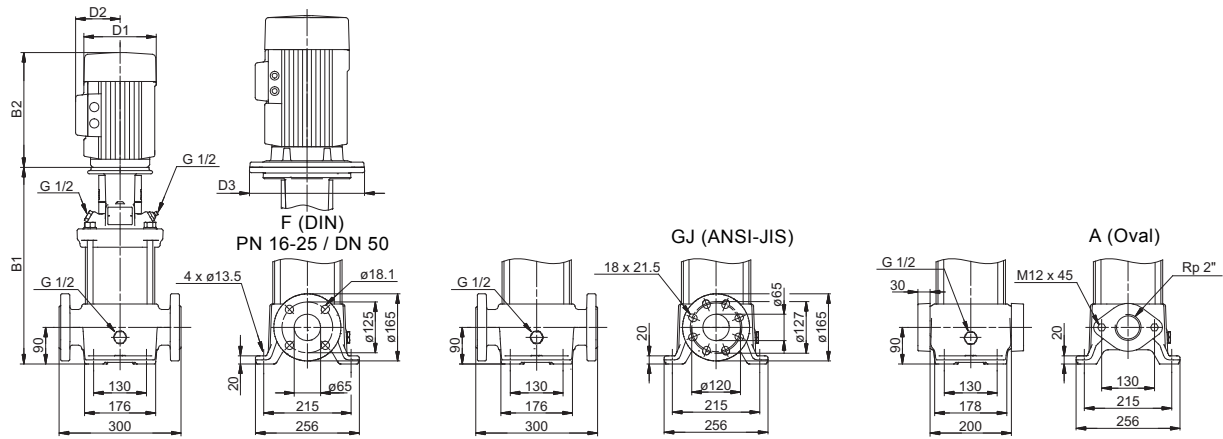

TM06 9597 2517

Dimensions and weights

Pump type	Motor P ₂ [kW]	CR								
		Dimension [mm]						Net weight [kg]		
		Oval flange		DIN flange		D1	D2	D3	Oval flange	DIN flange
		B1	B1+B2	B1	B1+B2					
CR 15-1	1.5	415	696	415	696	178	110	-	48	49
CR 15-2	3	420	755	420	755	198	120	-	55	56
CR 15-3	4	465	837	465	837	220	134	-	65	66
CR 15-4	5.5	542	933	542	933	220	134	300	87	88
CR 15-5	7.5	587	966	587	966	260	159	300	99	100
CR 15-6	11	-	-	709	1180	314	204	350	-	143
CR 15-7	11	-	-	754	1225	314	204	350	-	144
CR 15-8	11	-	-	799	1270	314	204	350	-	146
CR 15-9	15	-	-	844	1315	314	204	350	-	161
CR 15-10	15	-	-	889	1360	314	204	350	-	163
CR 15-12	18.5	-	-	979	1494	314	204	350	-	179

CRI, CRN 15

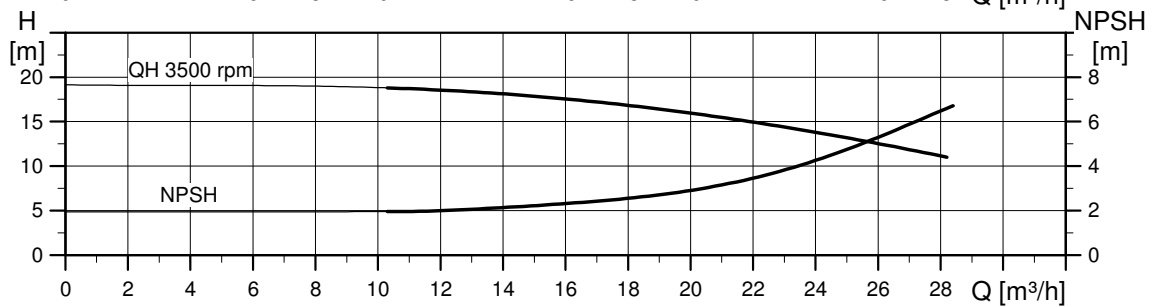
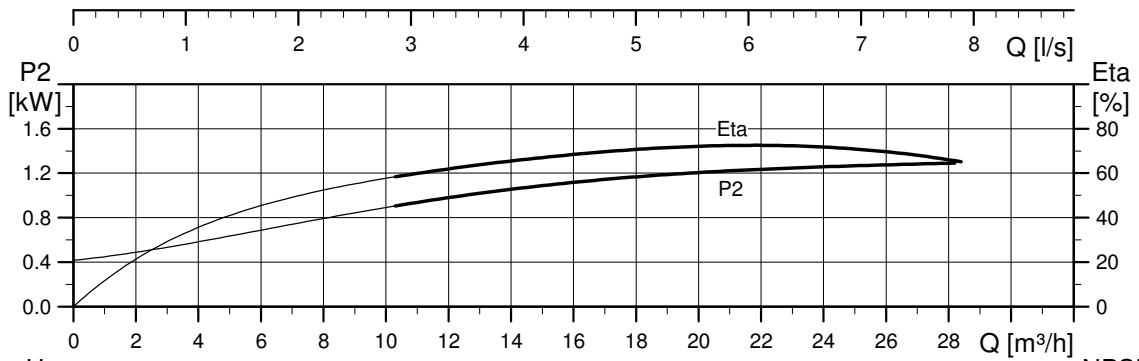
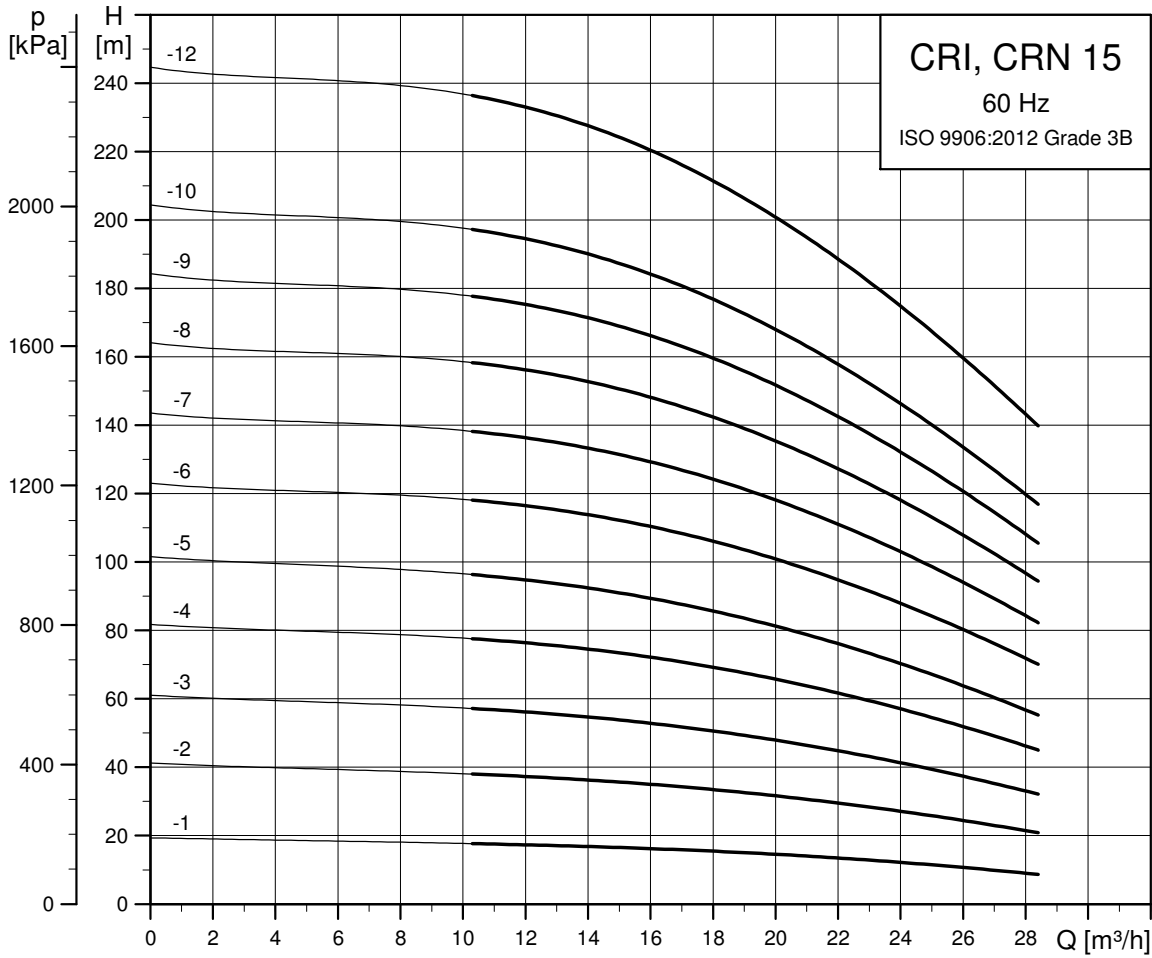

TM02 7319 0918

Dimensional sketch

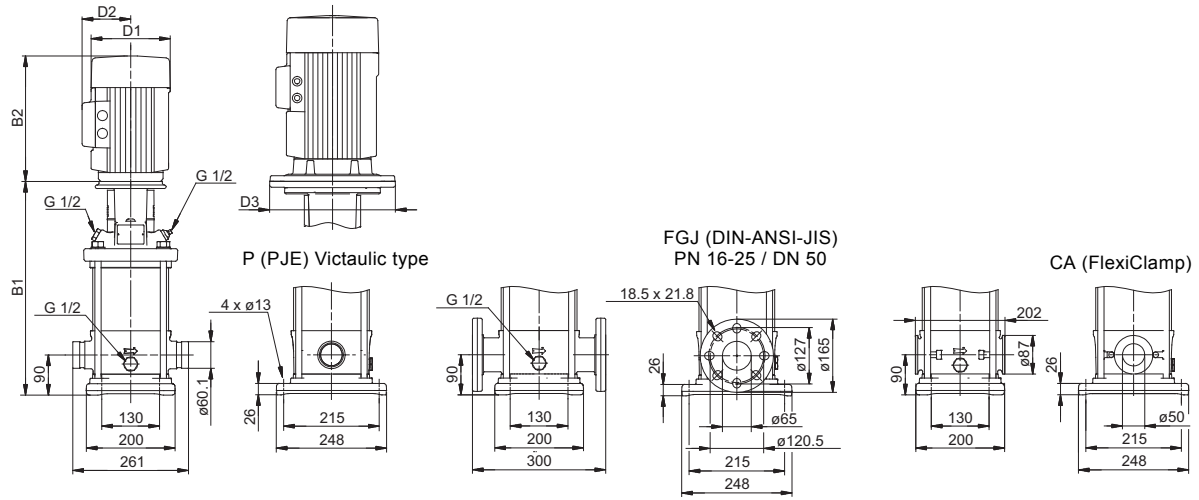

TM06 9598 2517

Dimensions and weights

Pump type	Motor P ₂ [kW]	CRI/CRN								Net weight [kg]	
		Dimension [mm]								PJE/CA	DIN flange
		PJE/CA		DIN flange		D1	D2	D3			
		B1	B1+B2	B1	B1+B2						
CRI/CRN 15-1	1.5	413	694	413	694	178	110	-	41	46	
CRI/CRN 15-2	3	418	753	418	753	198	120	-	49	53	
CRI/CRN 15-3	4	463	835	463	835	220	134	-	59	64	
CRI/CRN 15-4	5.5	540	931	540	931	220	134	300	81	86	
CRI/CRN 15-5	7.5	585	964	585	964	260	159	300	93	98	
CRI/CRN 15-6	11	707	1178	707	1178	314	204	350	135	140	
CRI/CRN 15-7	11	752	1223	752	1223	314	204	350	137	142	
CRI/CRN 15-8	11	797	1268	797	1268	314	204	350	138	143	
CRI/CRN 15-9	15	842	1313	842	1313	314	204	350	153	158	
CRI/CRN 15-10	15	887	1358	887	1358	314	204	350	155	160	
CRI/CRN 15-12	18.5	977	1492	977	1492	314	204	350	171	176	

CR 20

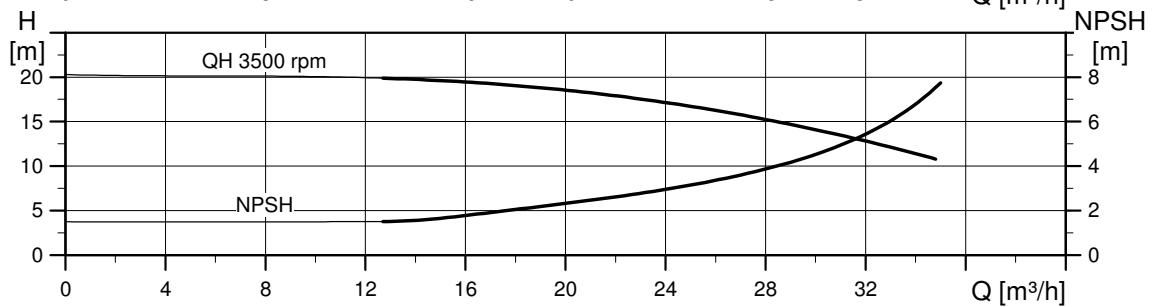
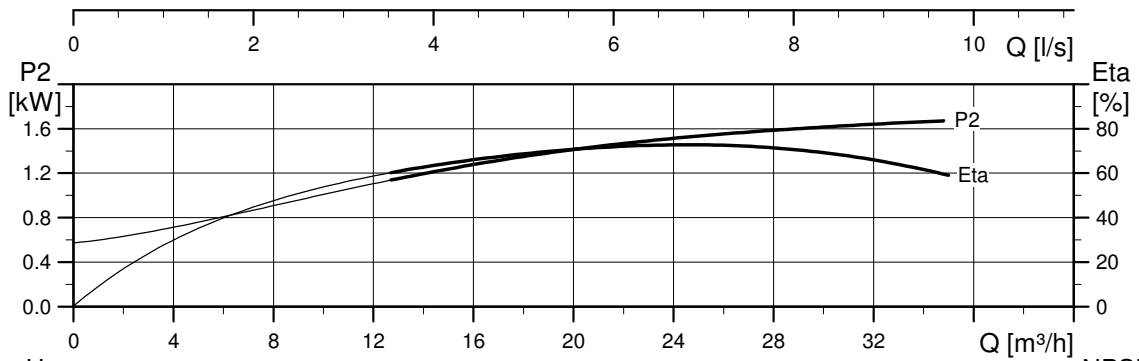
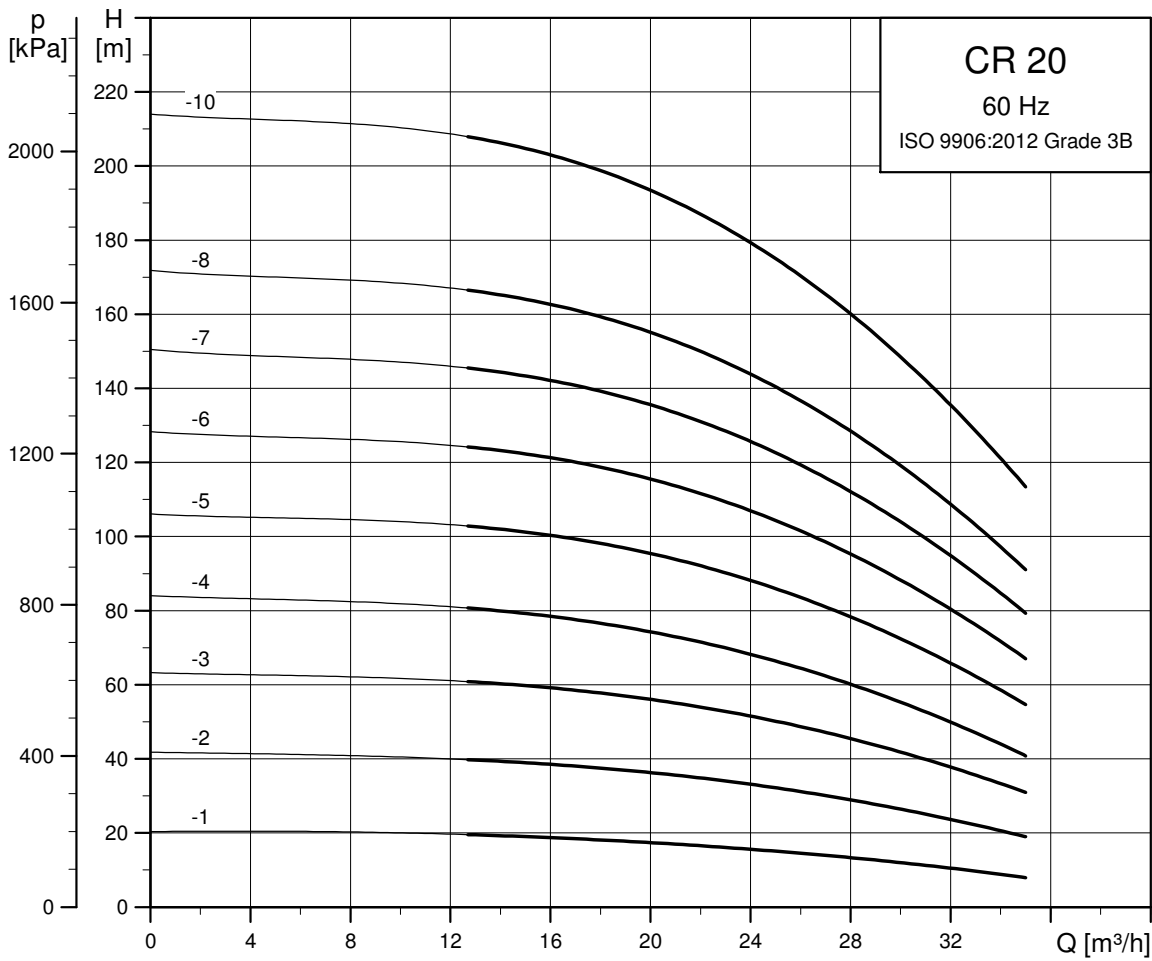

TM02 7320 09 18

Dimensional sketch

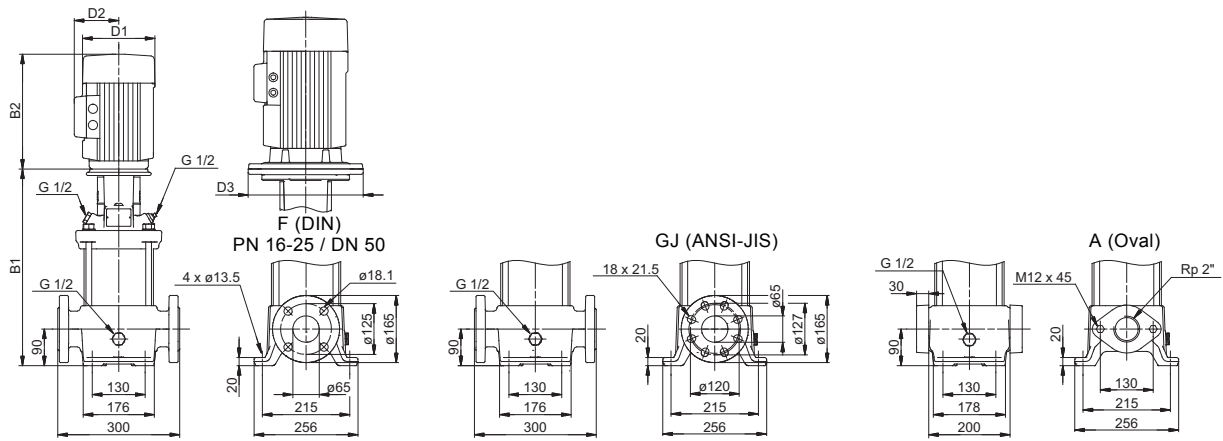

TM06 9597 2517

Dimensions and weights

Pump type	Motor P ₂ [kW]	CR								
		Dimension [mm]						Net weight [kg]		
		Oval flange		DIN flange		D1	D2	D3	Oval flange	DIN flange
		B1	B1+B2	B1	B1+B2					
CR 20-1	2.2	415	736	415	736	178	110	-	49	50
CR 20-2	4	420	792	420	792	220	134	-	64	65
CR 20-3	5.5	497	888	497	888	220	134	300	86	87
CR 20-4	7.5	542	921	542	921	260	159	300	98	99
CR 20-5	11	664	1135	664	1135	314	204	350	140	141
CR 20-6	11	-	-	709	1180	314	204	350	-	143
CR 20-7	15	-	-	754	1225	314	204	350	-	157
CR 20-8	15	-	-	799	1270	314	204	350	-	159
CR 20-10	18.5	-	-	889	1404	314	204	350	-	176

CRI, CRN 20

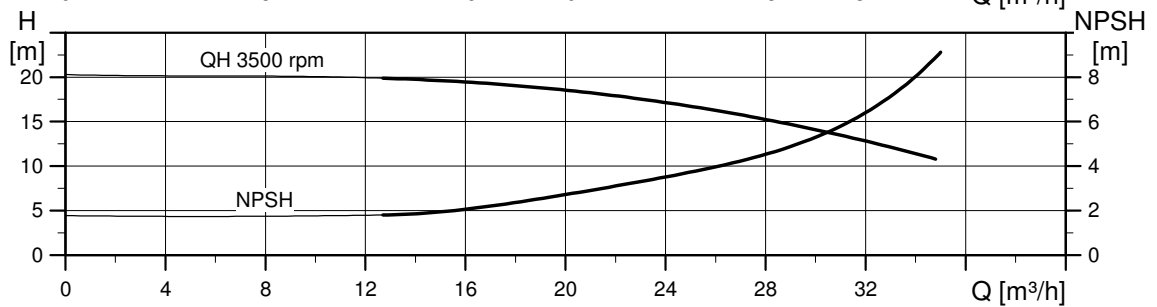
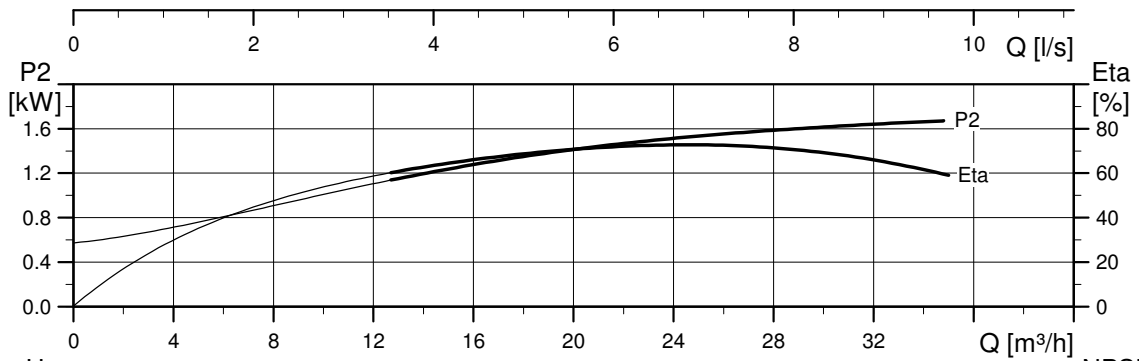
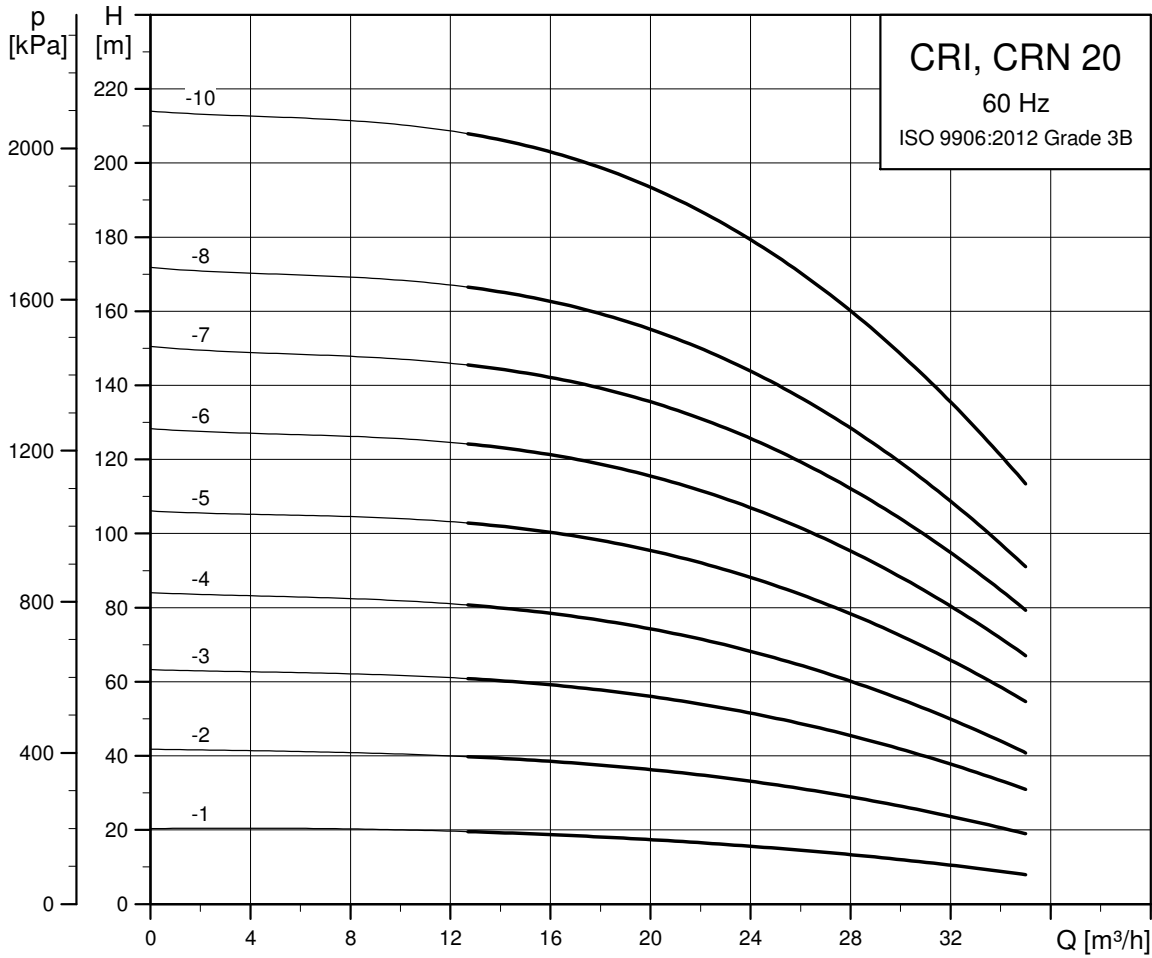

TM02 7321 0918

Dimensional sketch

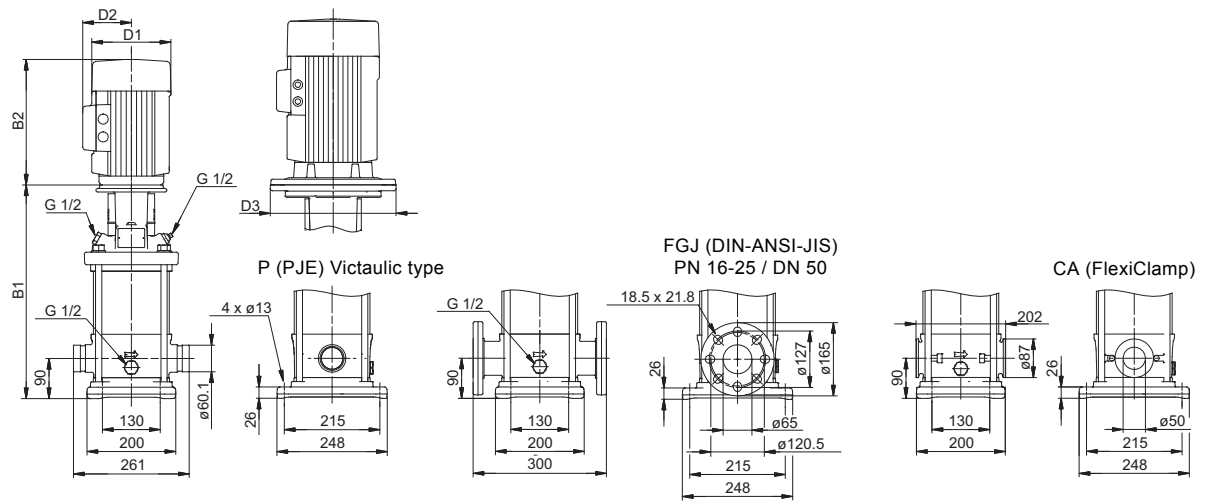

TM06 9598 2517

Dimensions and weights

Pump type	Motor P ₂ [kW]	CRI/CRN									
		Dimension [mm]								Net weight [kg]	
		PJE/CA		DIN flange		D1	D2	D3	PJE/CA	DIN flange	
		B1	B1+B2	B1	B1+B2						
CRI/CRN 20-1	2.2	413	734	413	734	178	110	-	42	47	
CRI/CRN 20-2	4	418	790	418	790	220	134	-	58	62	
CRI/CRN 20-3	5.5	495	886	495	886	220	134	300	79	84	
CRI/CRN 20-4	7.5	540	919	540	919	260	159	300	91	96	
CRI/CRN 20-5	11	662	1133	662	1133	314	204	350	133	138	
CRI/CRN 20-6	11	707	1178	707	1178	314	204	350	135	140	
CRI/CRN 20-7	15	752	1223	752	1223	314	204	350	150	155	
CRI/CRN 20-8	15	797	1268	797	1268	314	204	350	151	156	
CRI/CRN 20-10	18.5	887	1402	887	1402	314	204	350	168	173	

CR 32

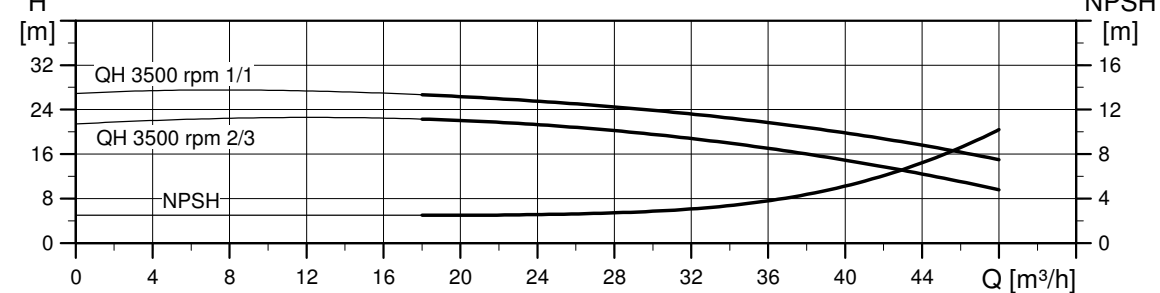
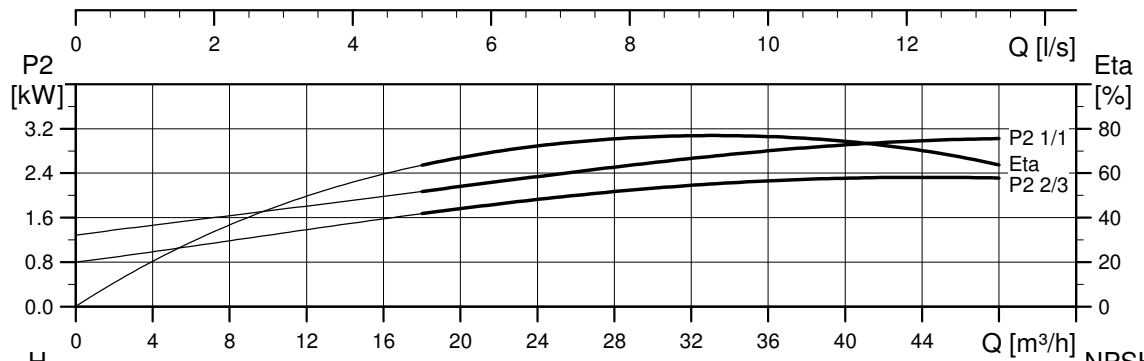
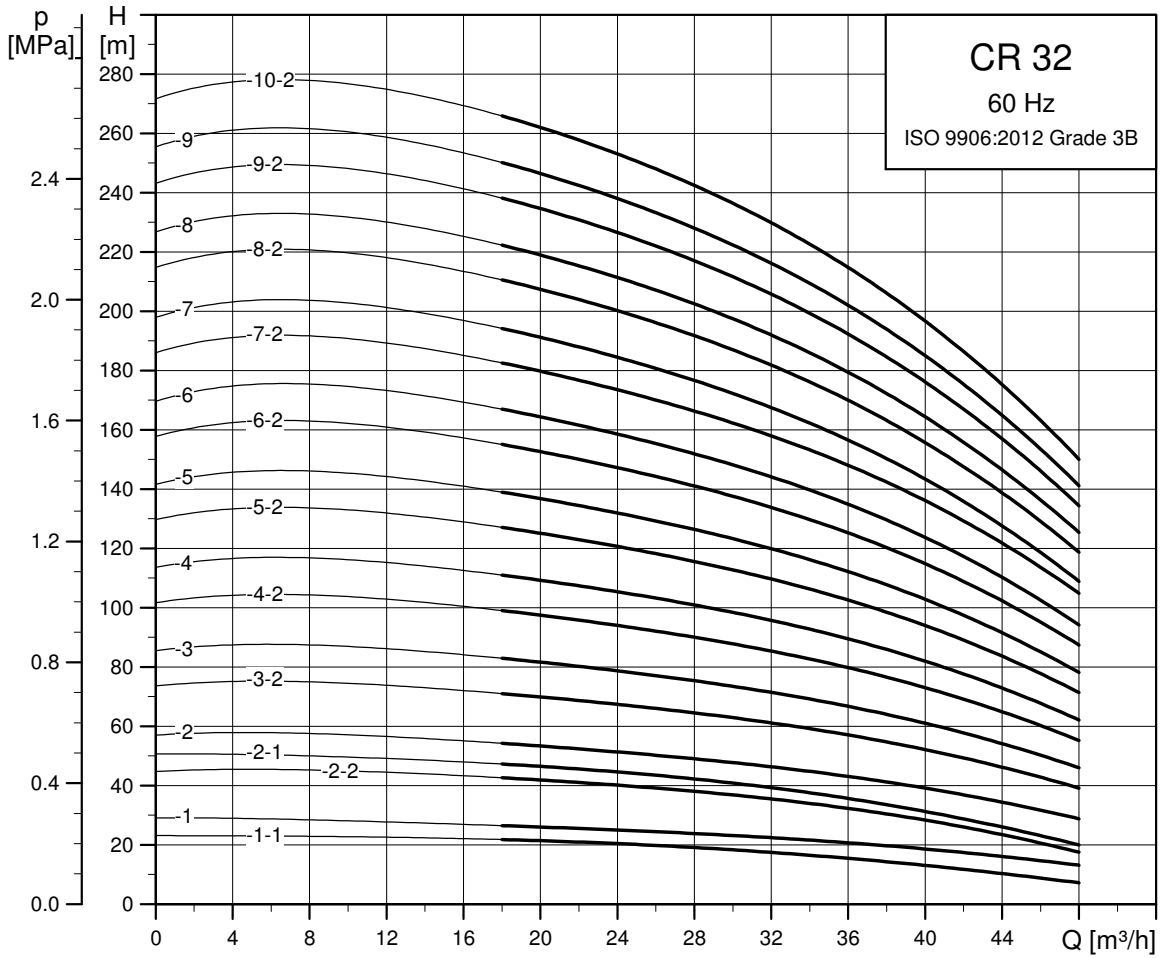

TM02 7322 0918

Dimensional sketch

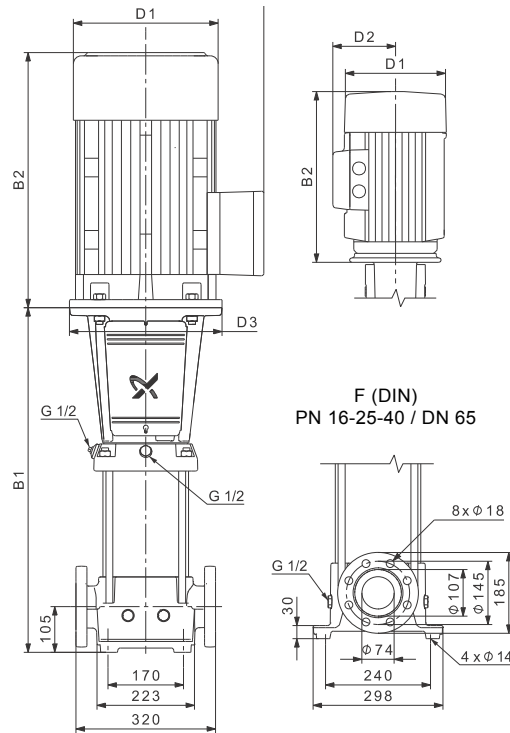

TM06 9605 2517

Dimensions and weights

Pump type	Motor P ₂ [kW]	CR					Net weight [kg]
		B1	B1+B2	D1	D2	D3	
CR 32-1-1	2.2	505	826	178	110	-	64
CR 32-1	3	505	840	198	120	-	70
CR 32-2-2	5.5	575	966	220	134	300	93
CR 32-2-1	5.5	575	966	220	134	300	93
CR 32-2	7.5	575	954	260	159	300	104
CR 32-3-2	11	755	1226	314	204	350	152
CR 32-3	11	755	1226	314	204	350	152
CR 32-4-2	11	825	1296	314	204	350	155
CR 32-4	15	825	1296	314	204	350	168
CR 32-5-2	15	895	1366	314	204	350	171
CR 32-5	18.5	895	1410	314	204	350	184
CR 32-6-2	18.5	965	1480	314	204	350	187
CR 32-6	18.5	965	1480	314	204	350	187
CR 32-7-2	22	1035	1576	314	204	350	204
CR 32-7	22	1035	1576	314	204	350	204
CR 32-8-2	30	1105	1716	396	315	400	327
CR 32-8	30	1105	1716	396	315	400	327
CR 32-9-2	30	1175	1786	396	315	400	330
CR 32-9	30	1175	1786	396	315	400	330
CR 32-10-2	30	1245	1856	396	315	400	334

CRN 32

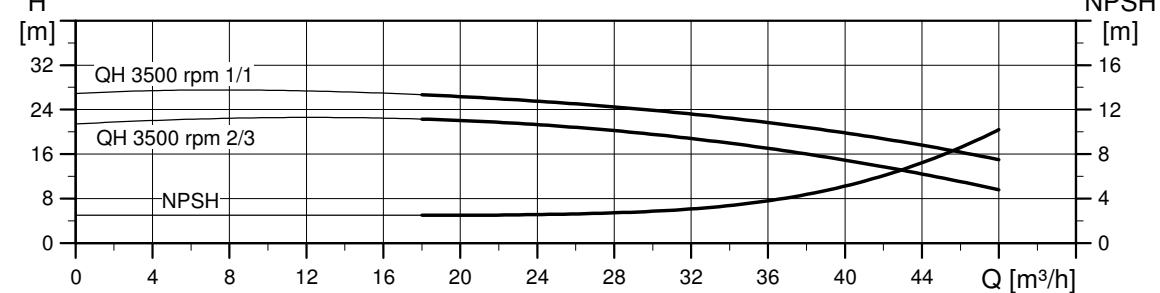
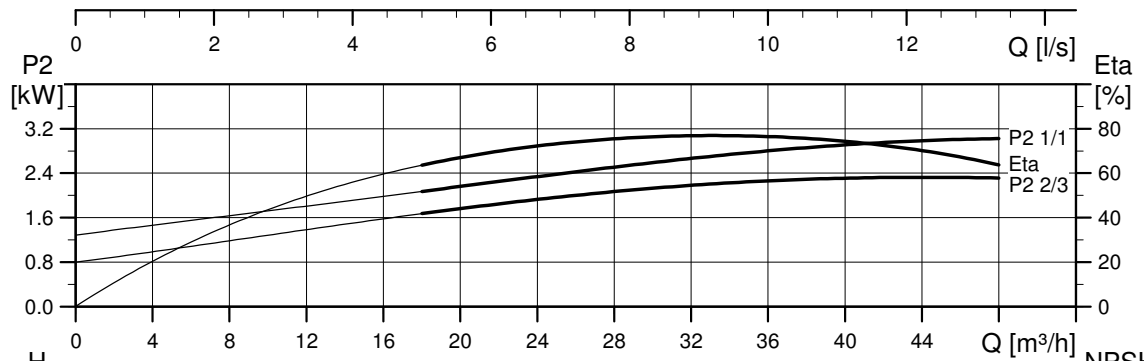
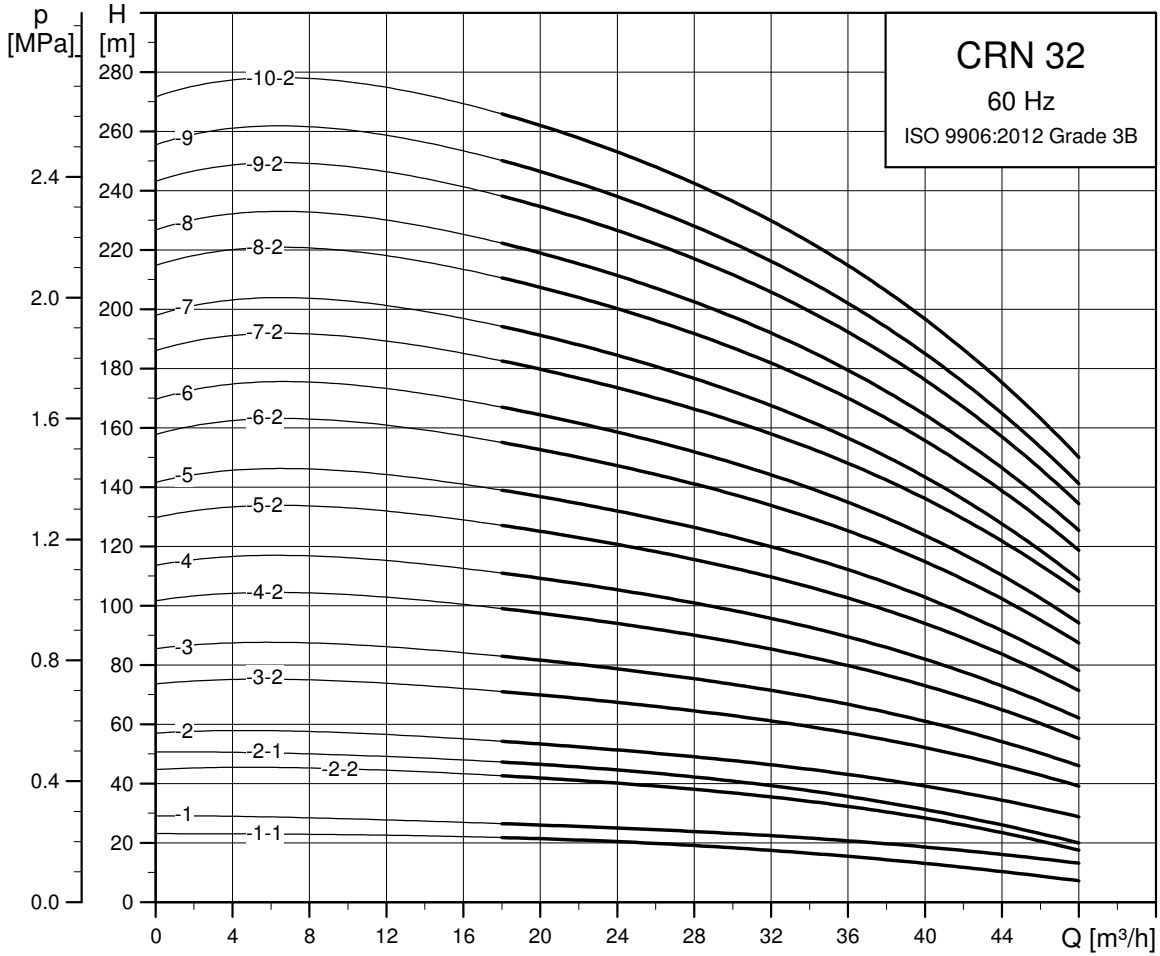

TM02 7323 0918

Dimensional sketch

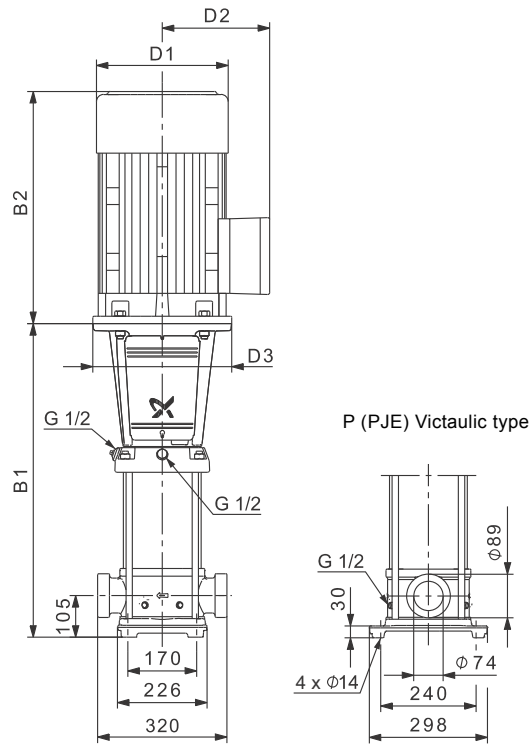

TM06 9191 1917

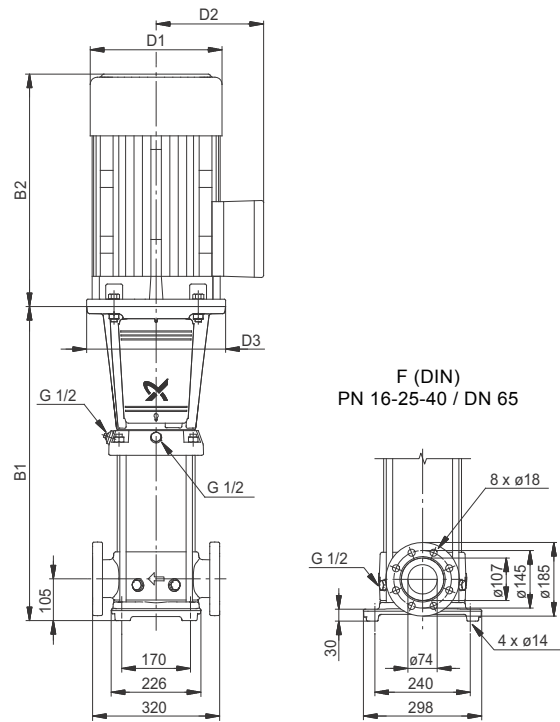

TM06 9599 2517

Dimensions and weights

Pump type	Motor P ₂ [kW]	CRN					Net weight [kg]
		B1	B1+B2	D1	D2	D3	
CRN 32-1-1	2.2	505	826	178	110	-	66
CRN 32-1	3	505	840	198	120	-	72
CRN 32-2-2	5.5	575	966	220	134	300	95
CRN 32-2-1	5.5	575	966	220	134	300	95
CRN 32-2	7.5	575	954	260	159	300	106
CRN 32-3-2	11	755	1226	314	204	350	154
CRN 32-3	11	755	1226	314	204	350	154
CRN 32-4-2	11	825	1296	314	204	350	157
CRN 32-4	15	825	1296	314	204	350	170
CRN 32-5-2	15	895	1366	314	204	350	173
CRN 32-5	18.5	895	1410	314	204	350	186
CRN 32-6-2	18.5	965	1480	314	204	350	189
CRN 32-6	18.5	965	1480	314	204	350	189
CRN 32-7-2	22	1035	1576	314	204	350	206
CRN 32-7	22	1035	1576	314	204	350	206
CRN 32-8-2	30	1105	1716	396	315	400	329
CRN 32-8	30	1105	1716	396	315	400	329
CRN 32-9-2	30	1175	1786	396	315	400	333
CRN 32-9	30	1175	1786	396	315	400	333
CRN 32-10-2	30	1245	1856	396	315	400	336

CR 45

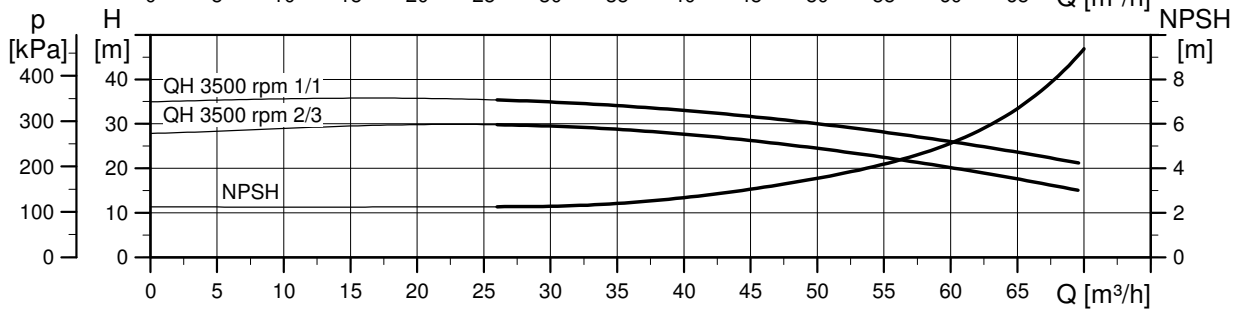
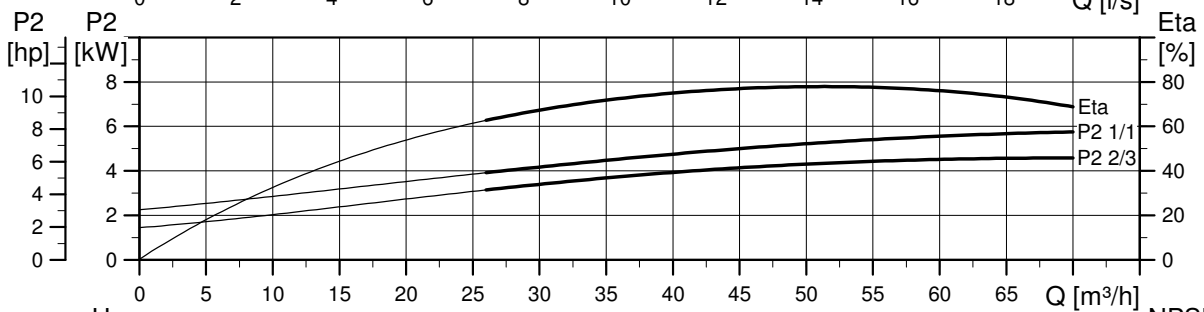
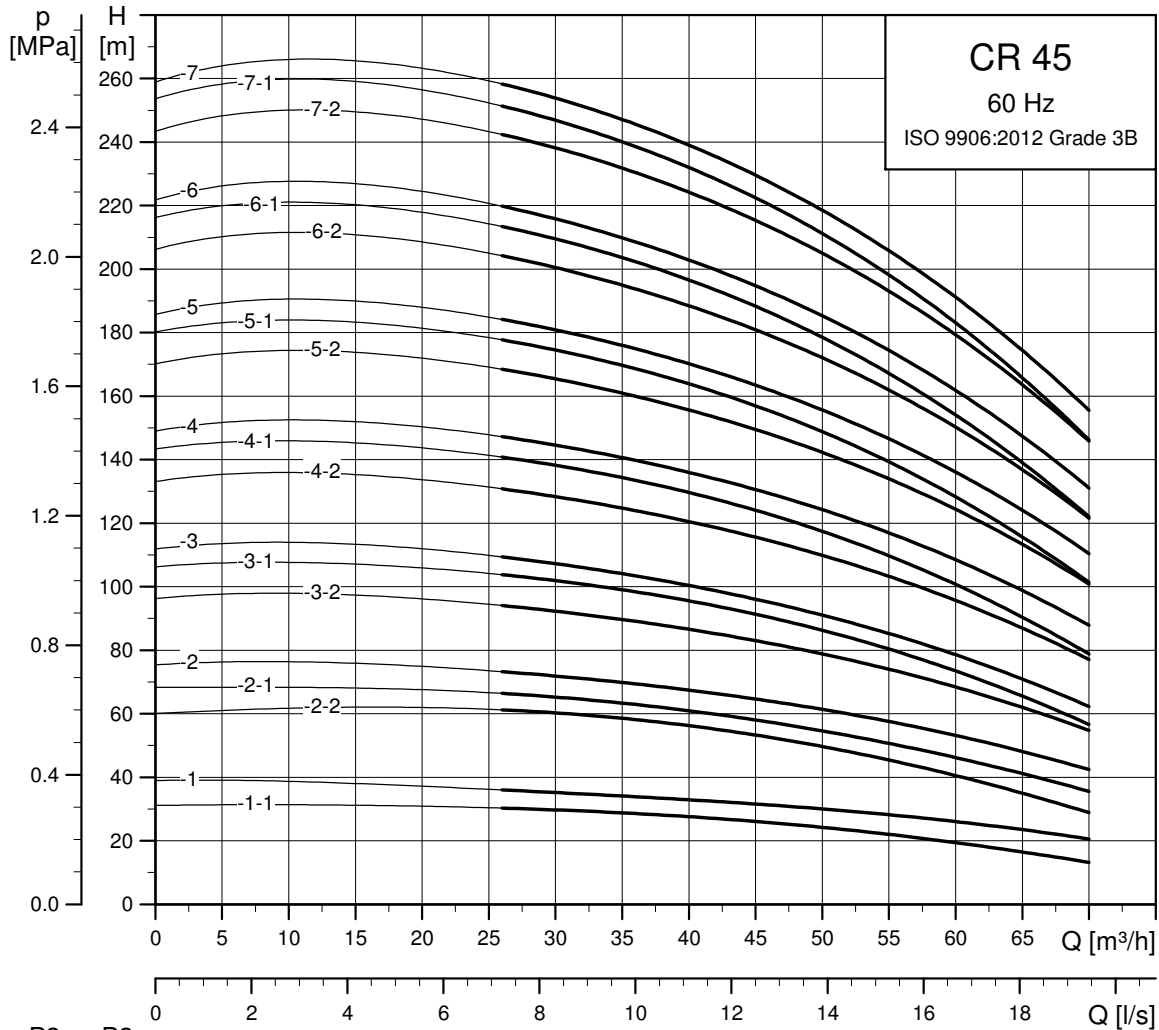

TM02 7324 0918

Dimensional sketch

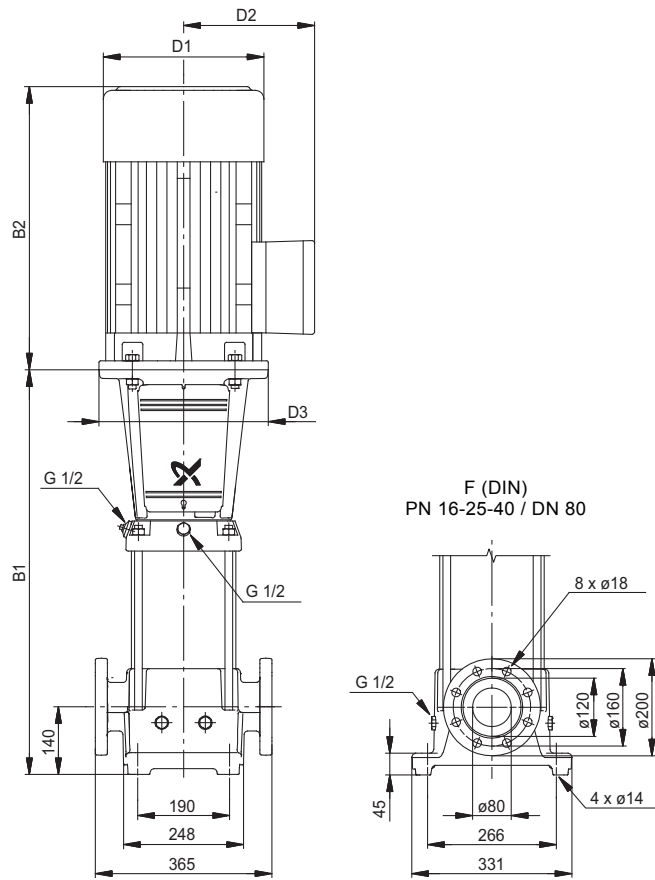

Dimensions and weights

Pump type	Motor P ₂ [kW]	CR					Net weight [kg]
		Dimension [mm]					
		B1	B1+B2	D1	D2	D3	
CR 45-1-1	5.5	559	950	220	134	300	100
CR 45-1	7.5	559	938	260	159	300	111
CR 45-2-2	11	749	1220	314	204	350	159
CR 45-2-1	11	749	1220	314	204	350	159
CR 45-2	15	749	1220	314	204	350	172
CR 45-3-2	18.5	829	1344	314	204	350	189
CR 45-3-1	18.5	829	1344	314	204	350	189
CR 45-3	18.5	829	1344	314	204	350	189
CR 45-4-2	22	909	1450	314	204	350	207
CR 45-4-1	30	909	1520	396	315	400	324
CR 45-4	30	909	1520	396	315	400	324
CR 45-5-2	30	989	1600	396	315	400	328
CR 45-5-1	30	989	1600	396	315	400	328
CR 45-5	30	989	1600	396	315	400	328
CR 45-6-2	37	1069	1705	396	315	400	349
CR 45-6-1	37	1069	1705	396	315	400	349
CR 45-6	37	1069	1705	396	315	400	349
CR 45-7-2	45	1149	1857	439	338	450	438
CR 45-7-1	45	1149	1857	439	338	450	438
CR 45-7	45	1149	1857	439	338	450	438

TM06 9600 2517

CRN 45

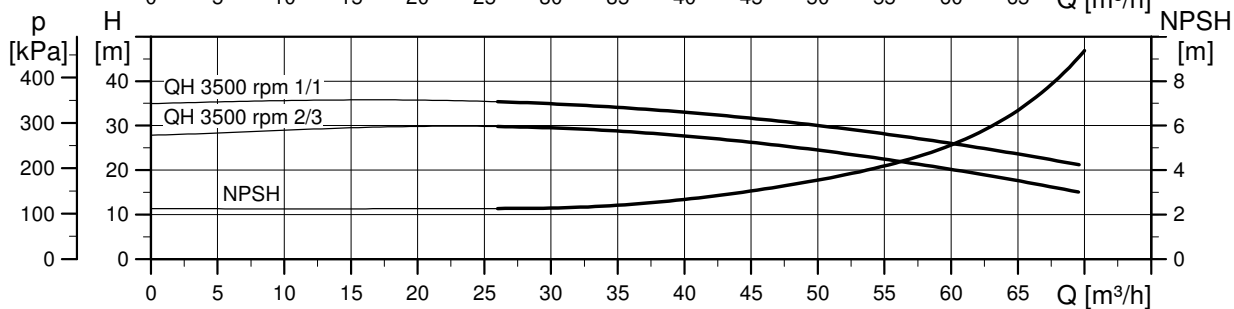
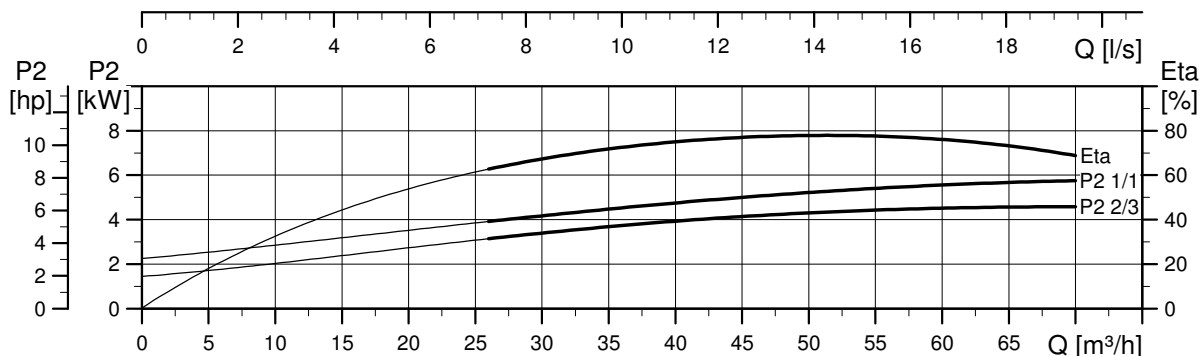
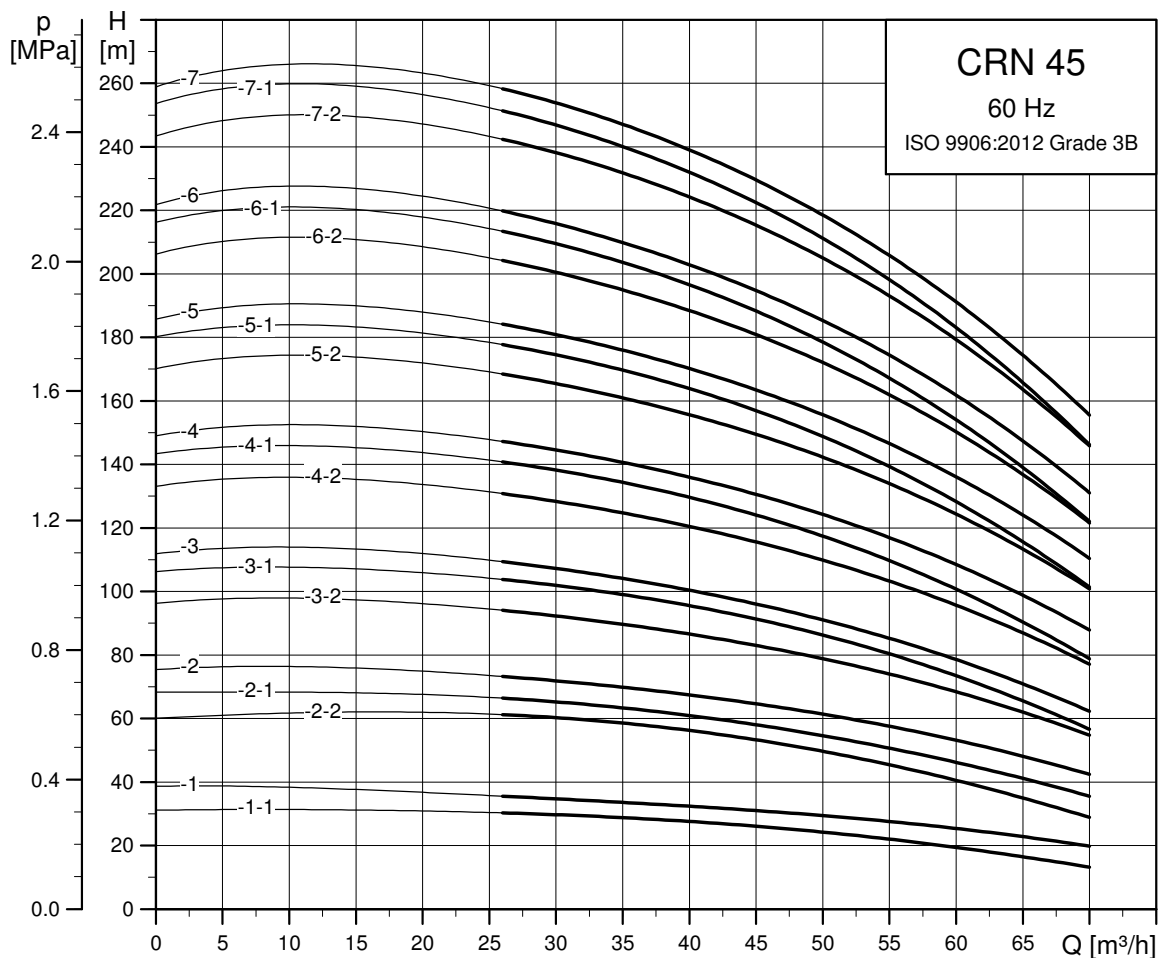

TM02 7325 0918

Dimensional sketch

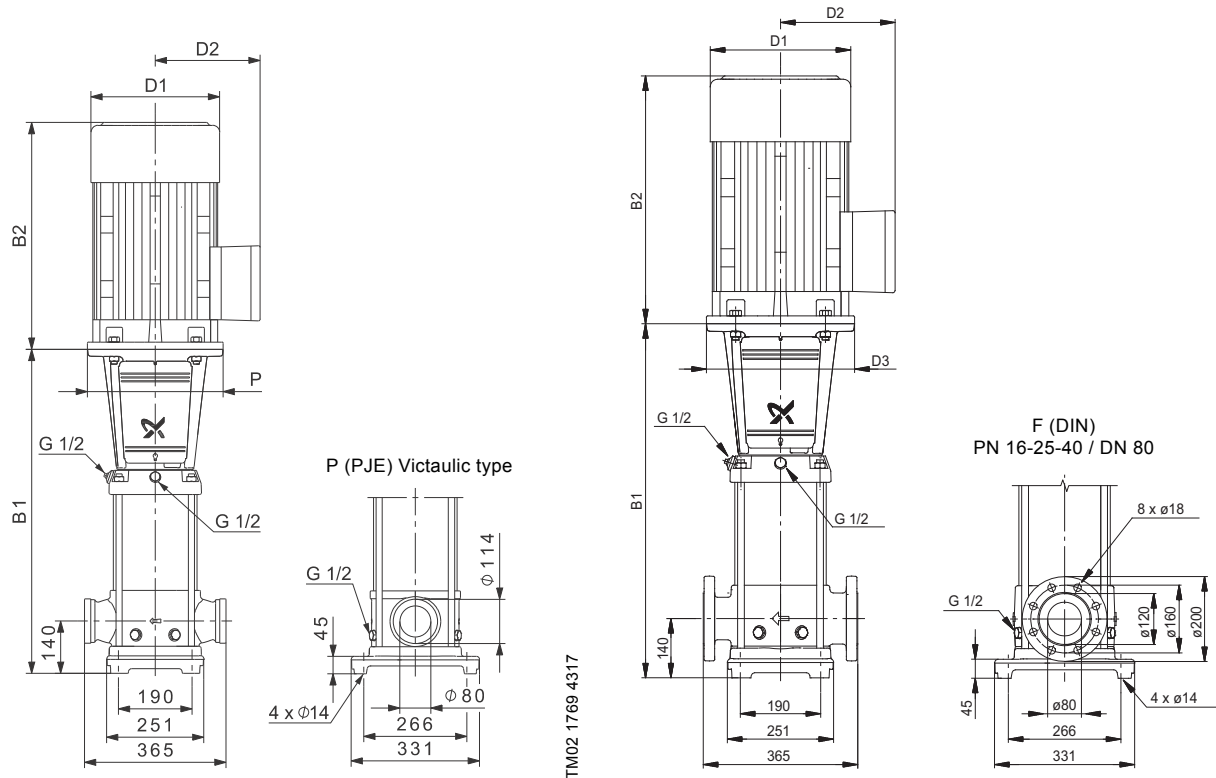

Dimensions and weights

Pump type	Motor P ₂ [kW]	CRN					Net weight [kg]
		B1	B1+B2	D1	D2	D3	
CRN 45-1-1	5.5	559	950	220	134	300	100
CRN 45-1	7.5	559	938	260	159	300	111
CRN 45-2-2	11	749	1220	314	204	350	160
CRN 45-2-1	11	749	1220	314	204	350	160
CRN 45-2	15	749	1220	314	204	350	173
CRN 45-3-2	18.5	829	1344	314	204	350	190
CRN 45-3-1	18.5	829	1344	314	204	350	190
CRN 45-3	18.5	829	1344	314	204	350	190
CRN 45-4-2	22	909	1450	314	204	350	207
CRN 45-4-1	30	909	1520	396	315	400	324
CRN 45-4	30	909	1520	396	315	400	324
CRN 45-5-2	30	989	1600	396	315	400	328
CRN 45-5-1	30	989	1600	396	315	400	328
CRN 45-5	30	989	1600	396	315	400	328
CRN 45-6-2	37	1069	1705	396	315	400	350
CRN 45-6-1	37	1069	1705	396	315	400	350
CRN 45-6	37	1069	1705	396	315	400	350
CRN 45-7-2	45	1149	1857	439	338	450	438
CRN 45-7-1	45	1149	1857	439	338	450	438
CRN 45-7	45	1149	1857	439	338	450	438

CR 64

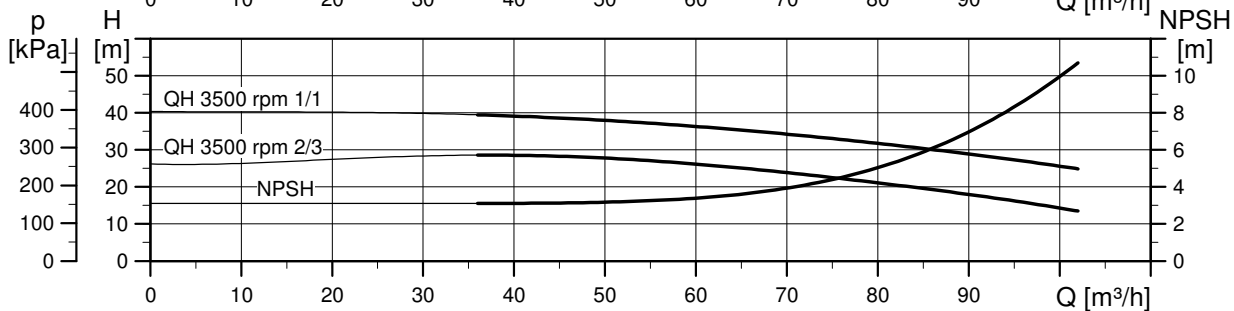
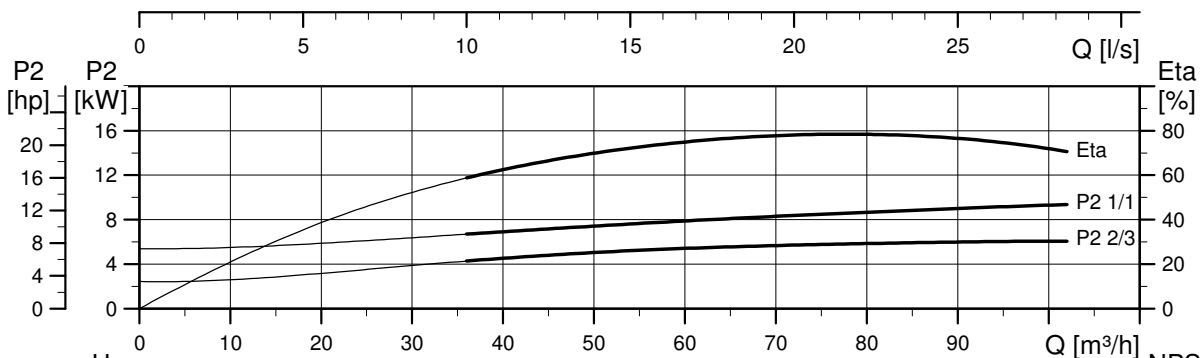
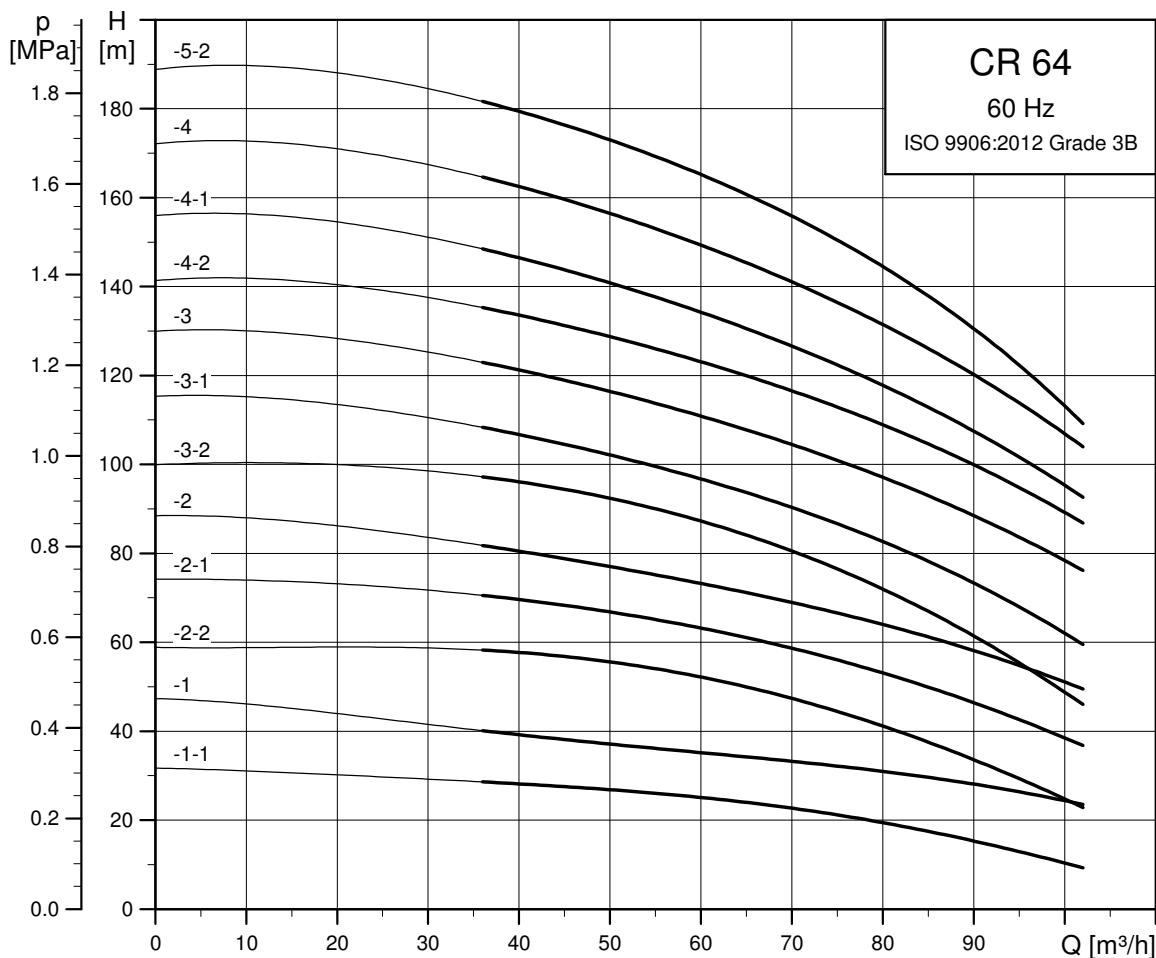

TM02 7326 0918

Dimensional sketch

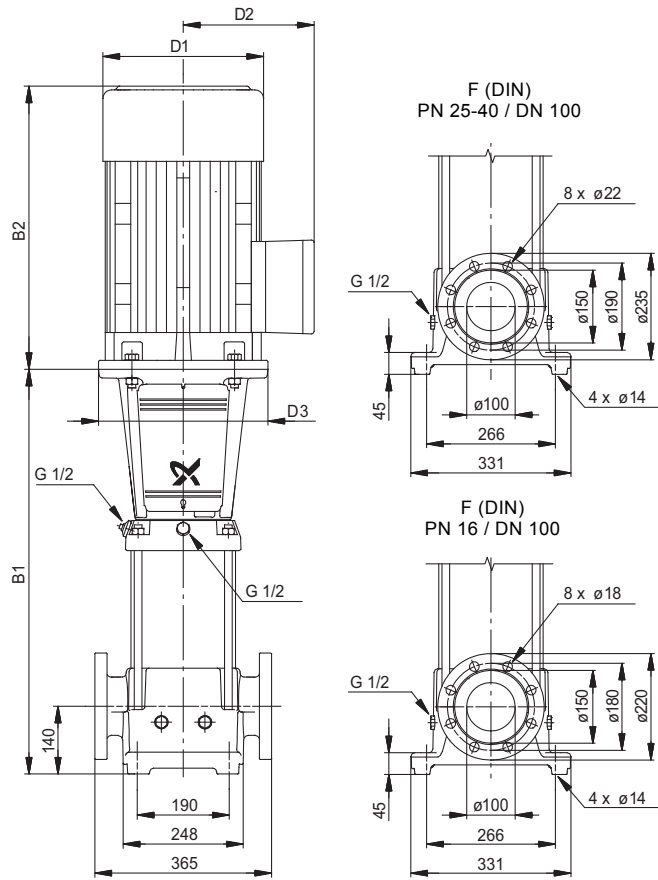

Dimensions and weights

Pump type	Motor P ₂ [kW]	CR					Net weight [kg]
		Dimension [mm]					
		B1	B1+B2	D1	D2	D3	
CR 64-1-1	7.5	561	940	260	159	300	113
CR 64-1	11	671	1142	314	204	350	158
CR 64-2-2	15	754	1225	314	204	350	175
CR 64-2-1	18.5	754	1269	314	204	350	188
CR 64-2	22	754	1295	314	204	350	202
CR 64-3-2	22	836	1377	314	204	350	207
CR 64-3-1	30	836	1447	396	315	400	324
CR 64-3	30	836	1447	396	315	400	324
CR 64-4-2	37	919	1555	396	315	400	345
CR 64-4-1	37	919	1555	396	315	400	345
CR 64-4	45	919	1627	439	338	450	429
CR 64-5-2	45	1001	1709	439	338	450	434

TM06 9606 2517

CRN 64

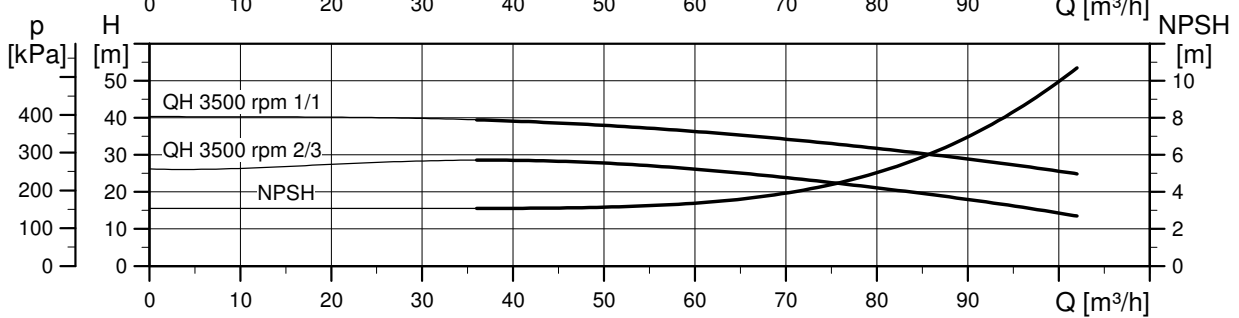
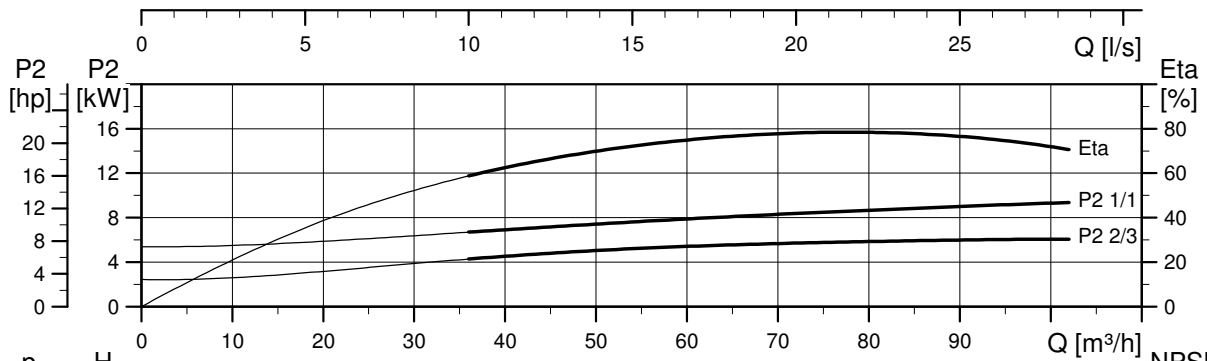
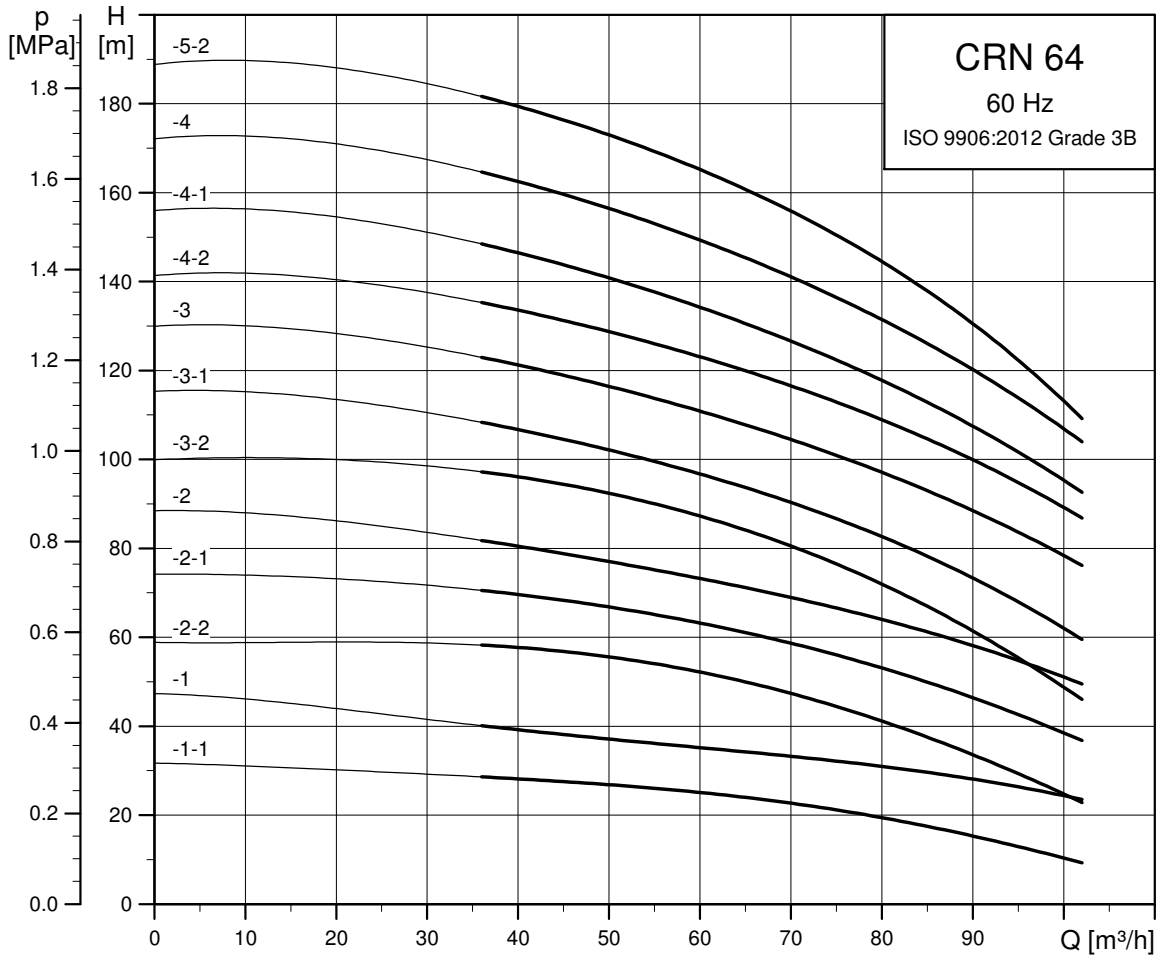

TM02 7327 0918

Dimensional sketch

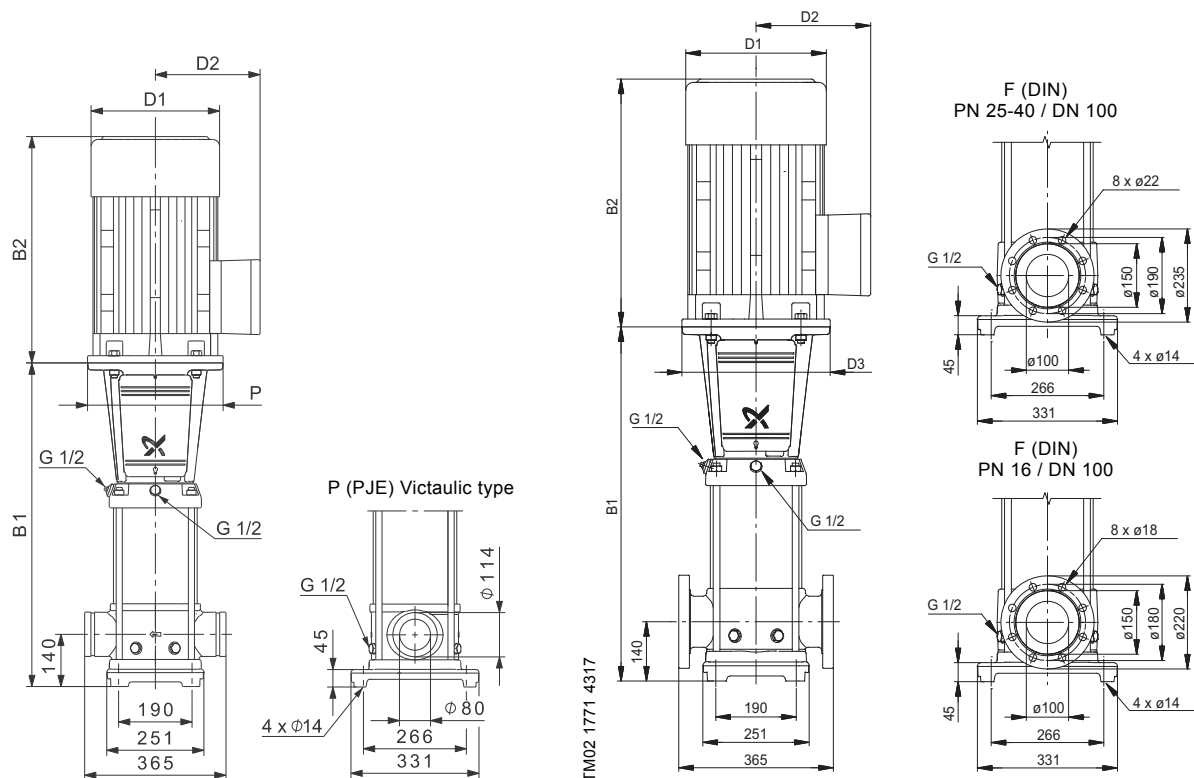

Dimensions and weights

Pump type	Motor P ₂ [kW]	CRN					Net weight [kg]
		B1	B1+B2	D1	D2	D3	
CRN 64-1-1	7.5	561	940	260	159	300	113
CRN 64-1	11	671	1142	314	204	350	158
CRN 64-2-2	15	754	1225	314	204	350	175
CRN 64-2-1	18.5	754	1269	314	204	350	188
CRN 64-2	22	754	1295	314	204	350	202
CRN 64-3-2	22	836	1377	314	204	350	206
CRN 64-3-1	30	836	1447	396	315	400	324
CRN 64-3	30	836	1447	396	315	400	324
CRN 64-4-2	37	919	1555	396	315	400	346
CRN 64-4-1	37	919	1555	396	315	400	346
CRN 64-4	45	919	1627	439	338	450	430
CRN 64-5-2	45	1001	1709	439	338	450	435

CR 95

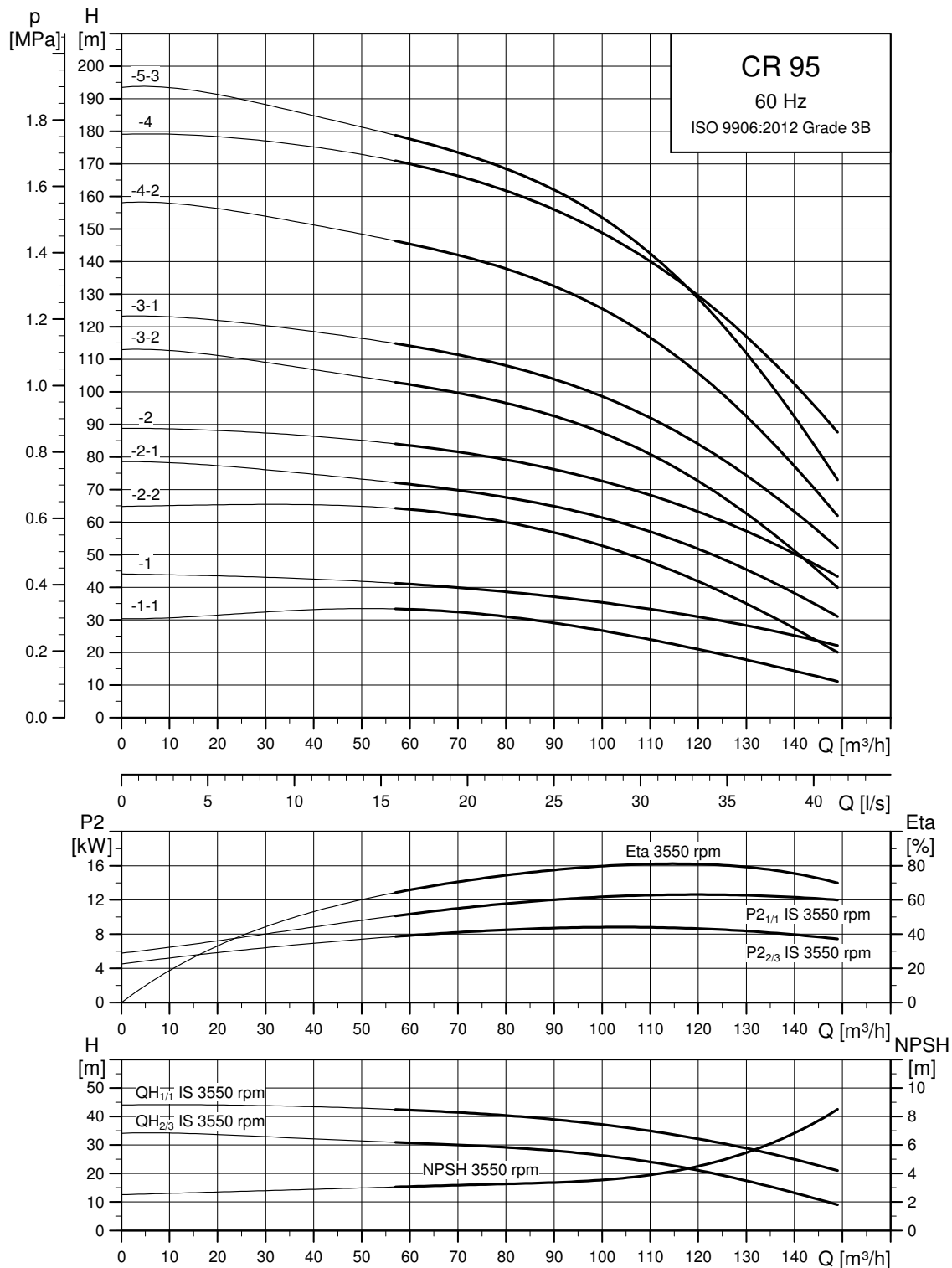

The maximum pump efficiency (ETA) is based on a three-stage pump.

TM06 5119 1318

Dimensional sketch

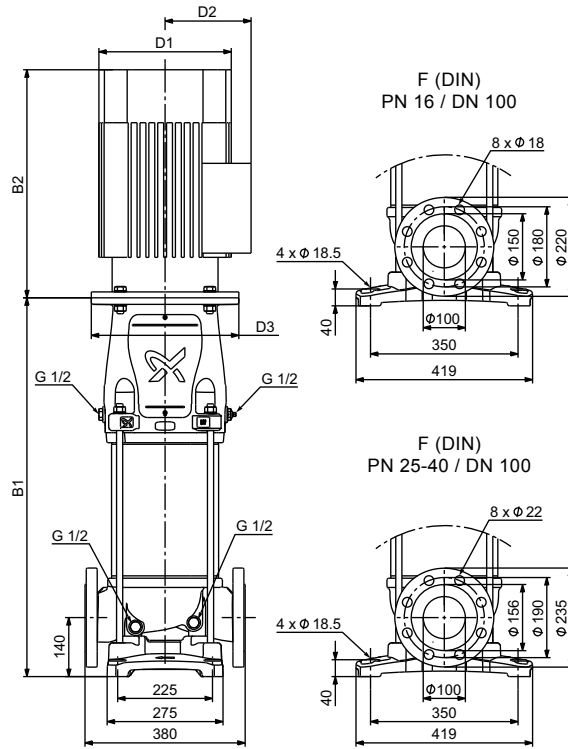

TM06 5174 1917

Dimensions and weights

Pump type	Motor P ₂ [kW]	CR					Net weight [kg]
		Dimension [mm]					
		B1	B1+B2	D1	D2	D3	
CR 95-1-1	11	691	1162	314	204	350	176
CR 95-1	15	691	1162	314	204	350	188
CR 95-2-2	18.5	795	1310	314	204	350	207
CR 95-2-1	22	795	1336	314	204	350	222
CR 95-2	30	800	1411	396	315	400	341
CR 95-3-2	30	905	1516	396	315	400	347
CR 95-3-1	37	905	1541	396	315	400	372
CR 95-4-2	45	1029	1737	449	338	450	454
CR 95-4	55	1028	1775	497	410	550	540
CR 95-5-3	55	1133	1880	497	410	550	546

CRN 95

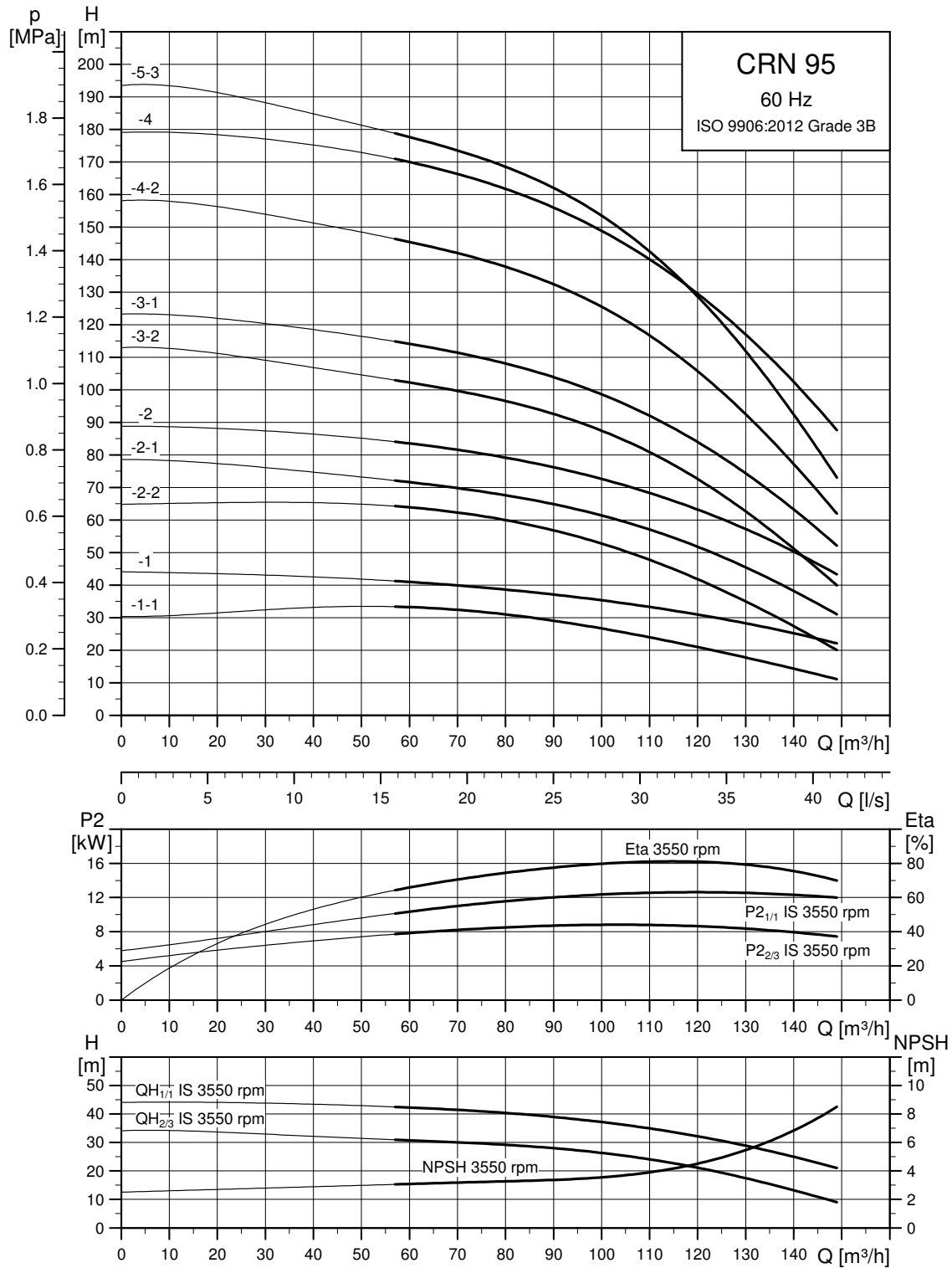

The maximum pump efficiency (ETA) is based on a three-stage pump.

TM06 5133 1318

Dimensional sketch

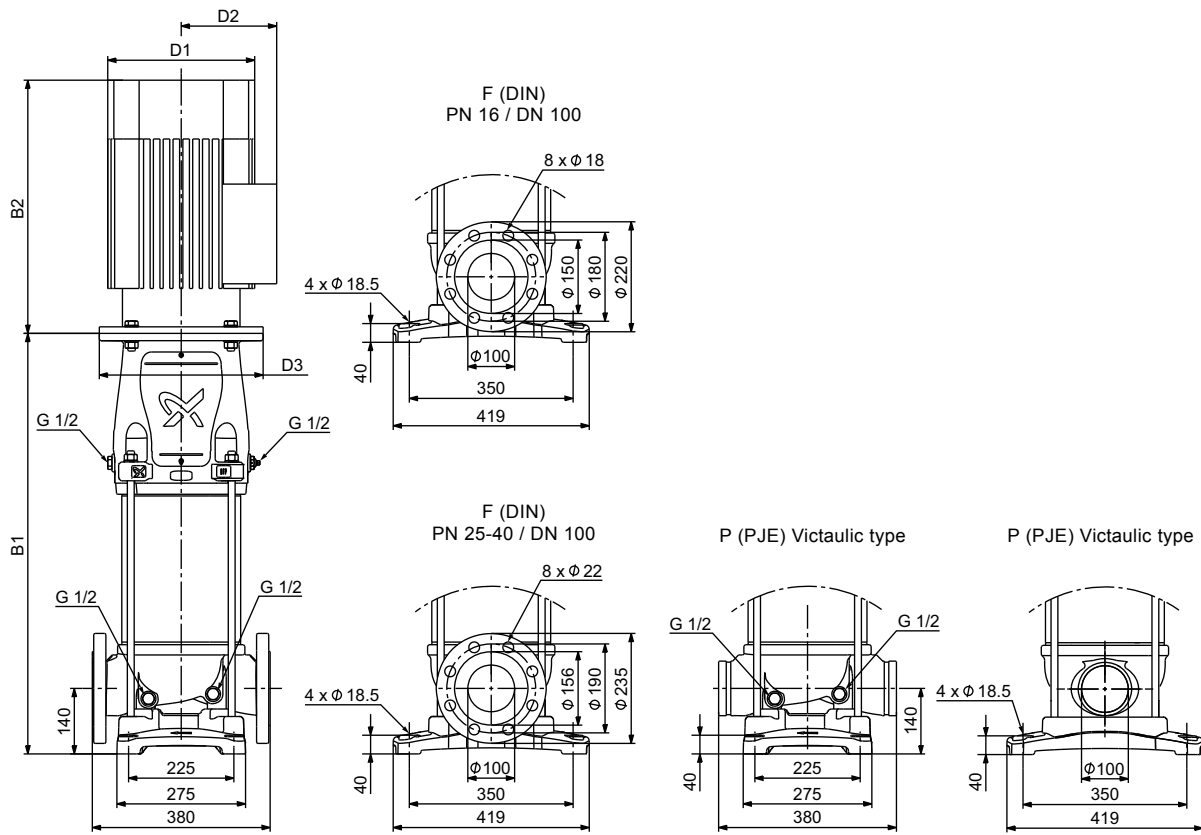

TM06 5094 1917

Dimensions and weights

Pump type	Motor P ₂ [kW]	CRN					Net weight [kg]
		Dimension [mm]					
		B1	B1+B2	D1	D2	D3	
CRN 95-1-1	11	691	1162	314	204	350	176
CRN 95-1	15	691	1162	314	204	350	188
CRN 95-2-2	18.5	795	1310	314	204	350	207
CRN 95-2-1	22	795	1336	314	204	350	222
CRN 95-2	30	800	1411	396	315	400	341
CRN 95-3-2	30	905	1516	396	315	400	347
CRN 95-3-1	37	905	1541	396	315	400	372
CRN 95-4-2	45	1029	1737	449	338	450	454
CRN 95-4	55	1028	1775	497	410	550	540
CRN 95-5-3	55	1133	1880	497	410	550	546

CR 125

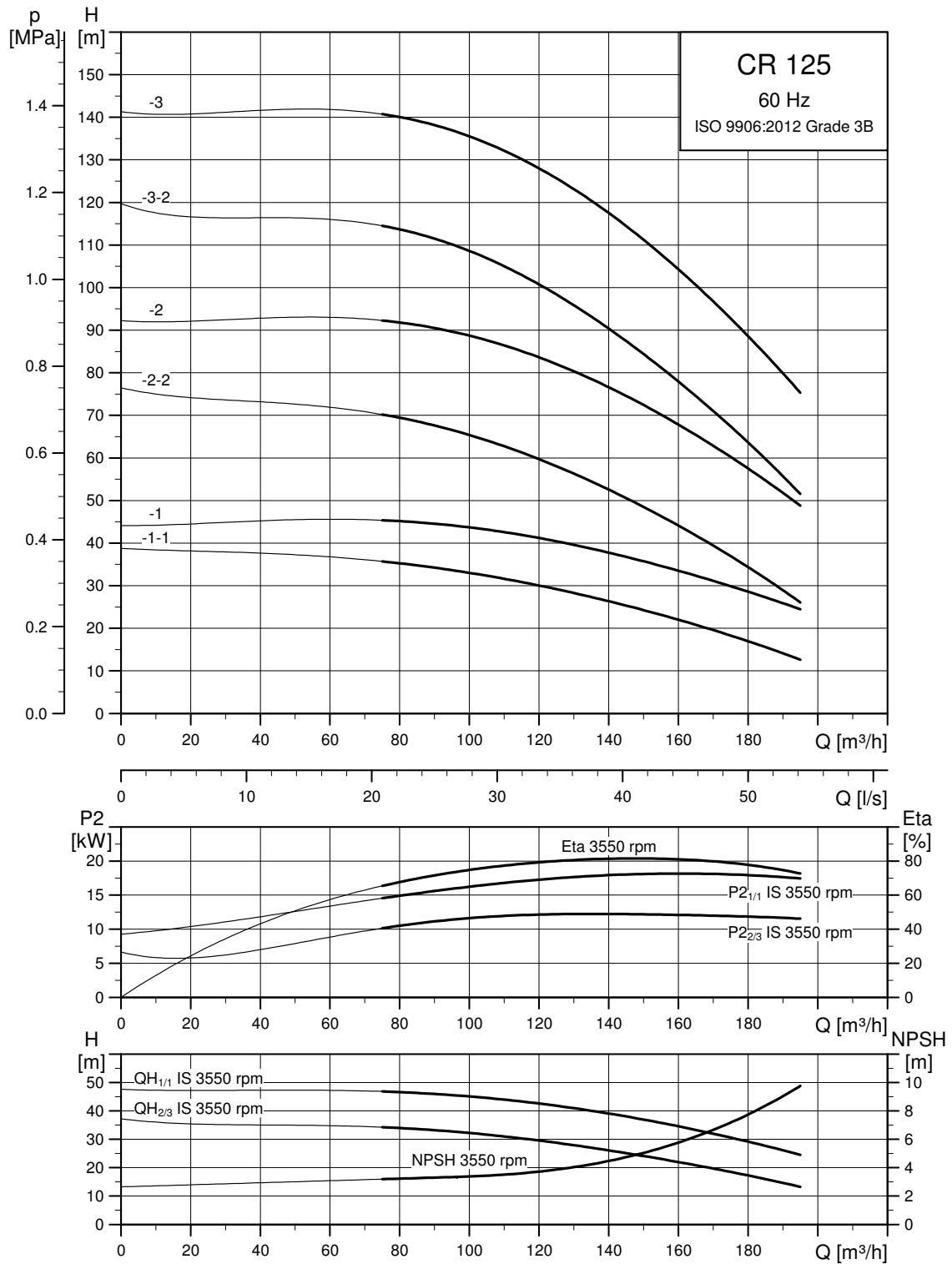

The maximum pump efficiency (ETA) is based on a three-stage pump.

TM06 5120 1318

Dimensional sketch

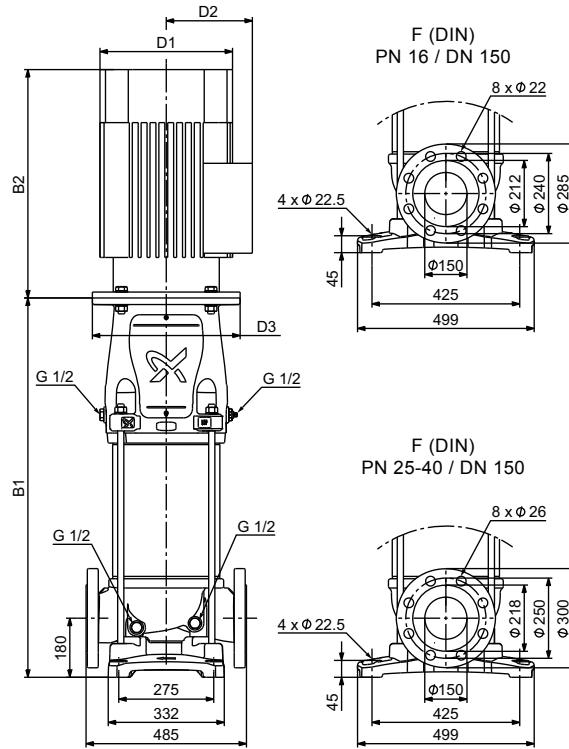

TM06 5175 4317

Dimensions and weights

Pump type	Motor P ₂ [kW]	CR					Net weight [kg]
		Dimension [mm]					
		B1	B1+B2	D1	D2	D3	
CR 125-1-1	15	783	1254	314	204	350	229
CR 125-1	18.5	783	1298	314	204	350	242
CR 125-2-2	30	907	1518	396	315	400	383
CR 125-2	37	907	1543	396	315	400	408
CR 125-3-2	45	1052	1760	449	338	450	495
CR 125-3	55	1050	1797	497	410	550	584

CRN 125

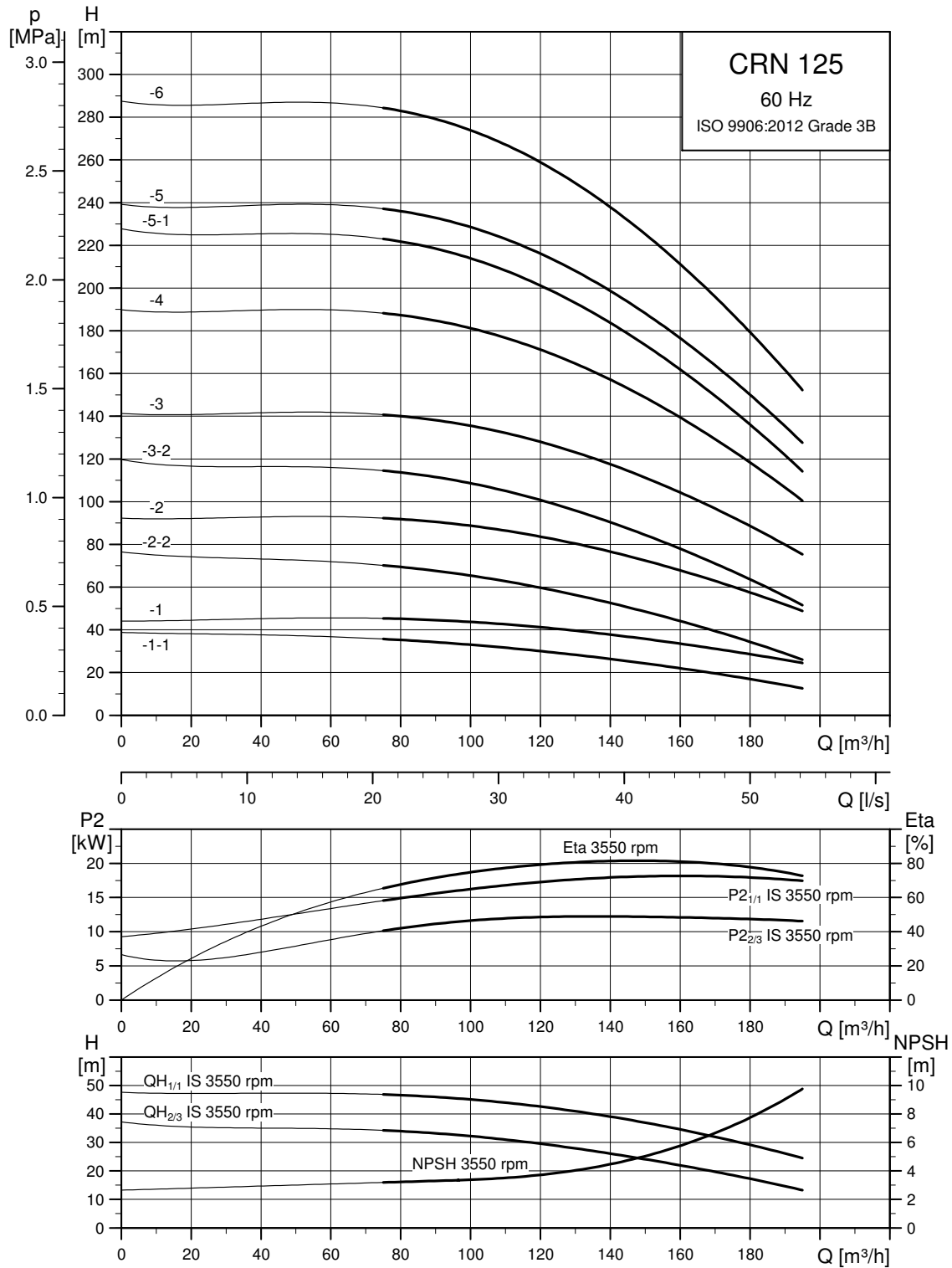

The maximum pump efficiency (ETA) is based on a three-stage pump.

TM06 5134 1318

Dimensional sketch

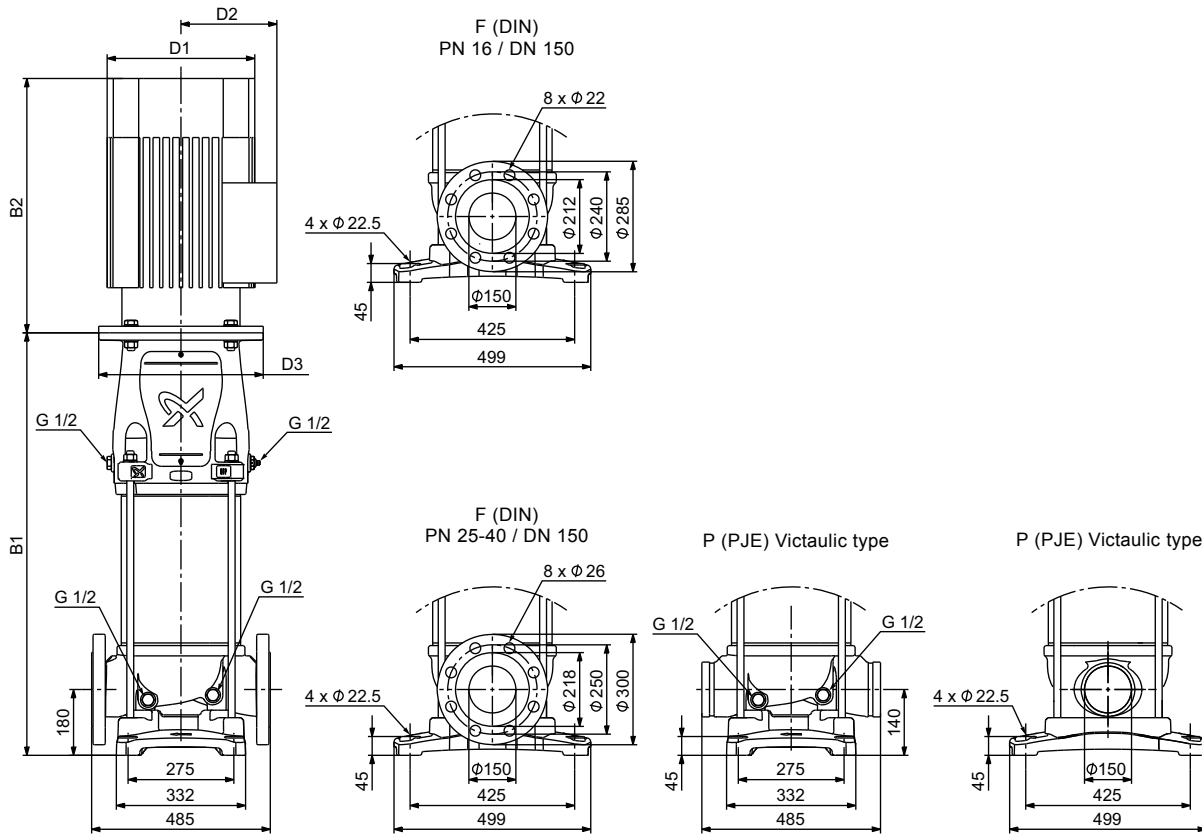

TM06 5095 4317

Dimensions and weights

Pump type	Motor P ₂ [kW]	CRN					Net weight [kg]
		Dimension [mm]					
		B1	B1+B2	D1	D2	D3	
CRN 125-1-1	15	783	1254	314	204	350	229
CRN 125-1	18.5	783	1298	314	204	350	242
CRN 125-2-2	30	907	1518	396	315	400	383
CRN 125-2	37	907	1543	396	315	400	408
CRN 125-3-2	45	1052	1760	449	338	450	495
CRN 125-3	55	1050	1797	497	410	550	584
CRN 125-4	75	1172	1992	551	433	550	704
CRN 125-5-1	90	1294	2224	551	433	550	799
CRN 125-5	110	1324	2236	616	515	660	985
CRN 125-6	110	1446	2358	616	515	660	995

CR 155

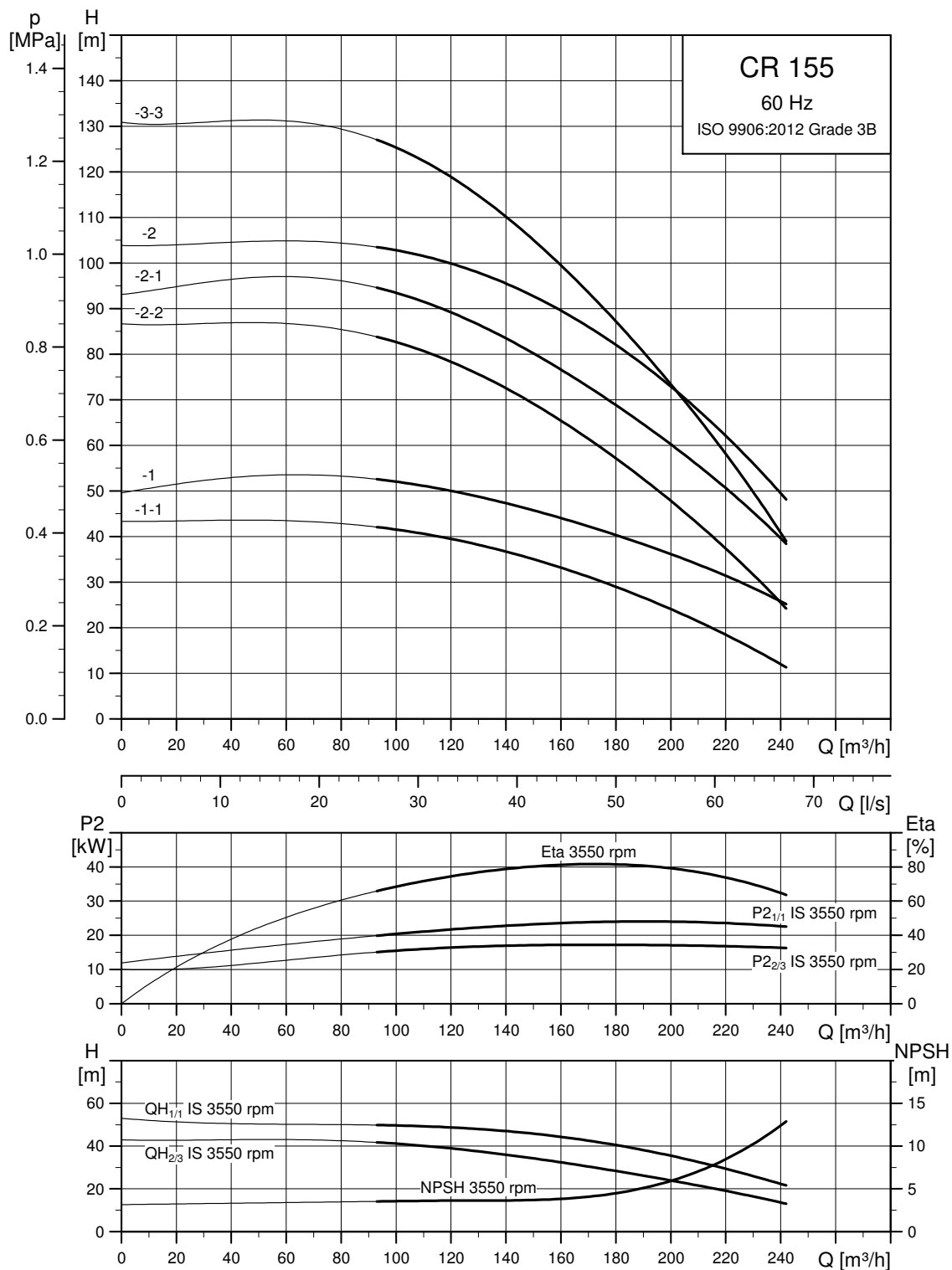

Preliminary performance curves.
The maximum pump efficiency (ETA) is calculated and based on a three-stage pump.

TM06 5121 1318

Dimensional sketch

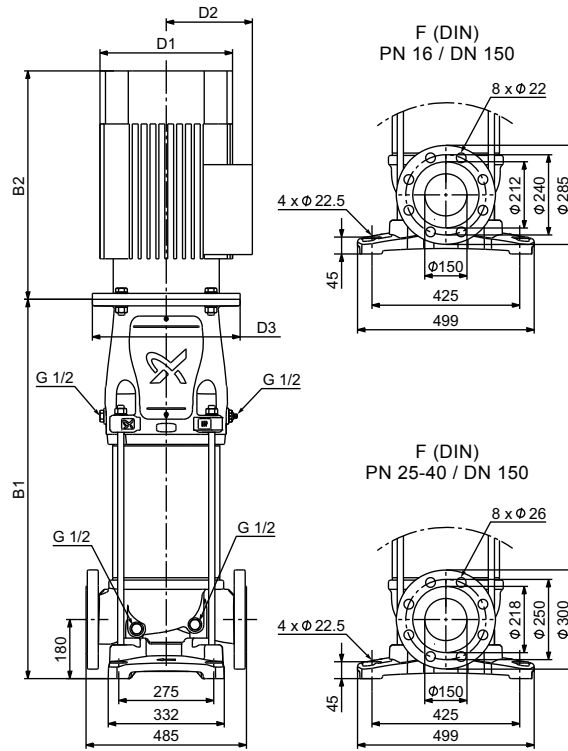

TM06 5175 4317

Dimensions and weights

Pump type	Motor P ₂ [kW]	CR					Net weight [kg]
		Dimension [mm]					
		B1	B1+B2	D1	D2	D3	
CR 155-1-1	18.5	783	1298	314	204	350	242
CR 155-1	30	785	1396	396	315	400	373
CR 155-2-2	37	907	1543	396	315	400	409
CR 155-2-1	45	930	1638	449	338	450	486
CR 155-2	55	928	1675	497	410	550	575
CR 155-3-3	55	1050	1797	497	410	550	585

CRN 155

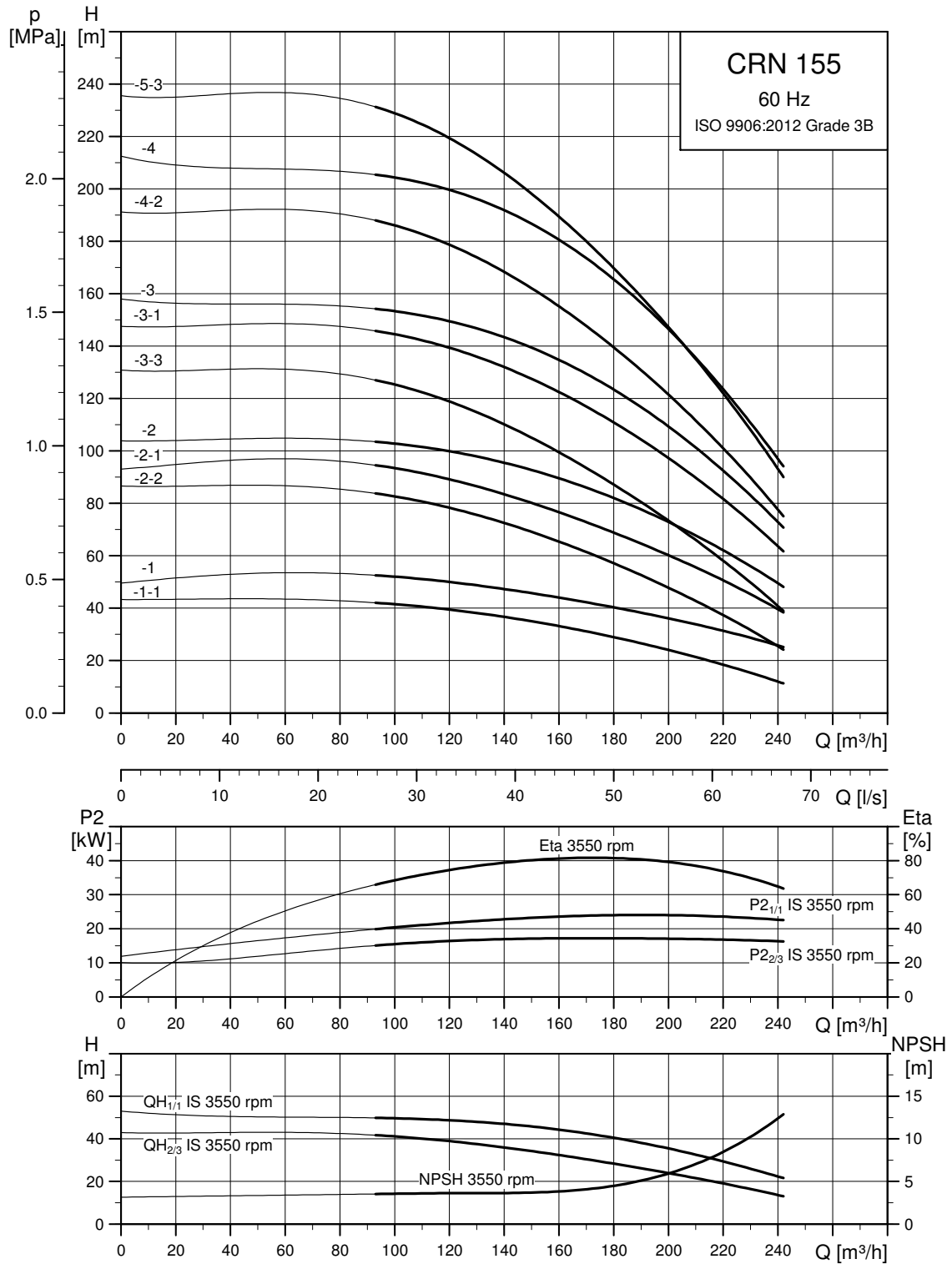

Preliminary performance curves.
The maximum pump efficiency (ETA) is calculated and based on a three-stage pump.

TM06 5135 1318

Dimensional sketch

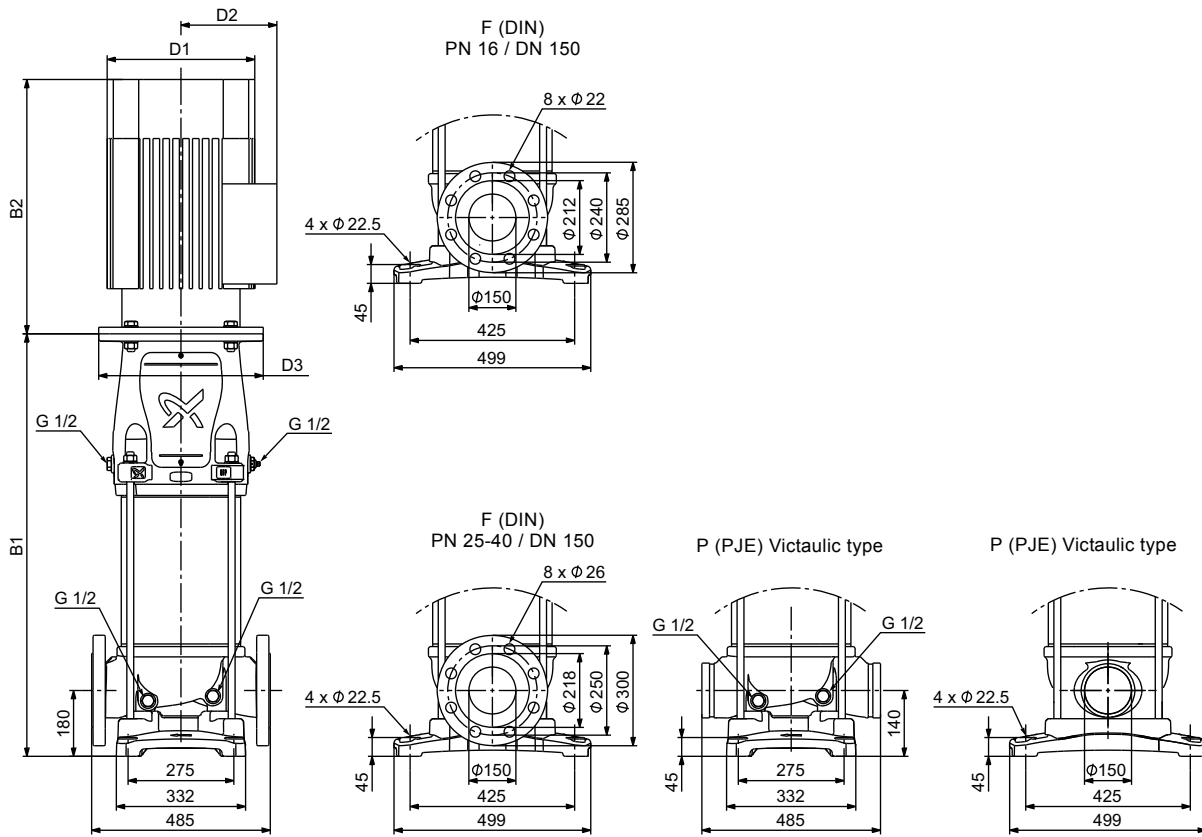

TN06 5095 4317

Dimensions and weights

Pump type	Motor P ₂ [kW]	CRN					Net weight [kg]
		Dimension [mm]					
		B1	B1+B2	D1	D2	D3	
CRN 155-1-1	18.5	783	1298	314	204	350	242
CRN 155-1	30	785	1396	396	315	400	373
CRN 155-2-2	37	907	1543	396	315	400	409
CRN 155-2-1	45	930	1638	449	338	450	486
CRN 155-2	55	928	1675	497	410	550	575
CRN 155-3-3	55	1050	1797	497	410	550	585
CRN 155-3-1	75	1050	1870	551	433	550	695
CRN 155-3	90	1050	1980	551	433	550	780
CRN 155-4-2	90	1172	2102	551	433	550	791
CRN 155-4	110	1202	2114	616	515	660	977
CRN 155-5-3	110	1324	2236	616	515	660	987

6. Motor data

Standard motors for CR, CRI, CRN, 60 Hz

MG



TM03 1711 2805

Motor P2 [kW]	Frame size	Standard voltage [V]	I _{1/1} [A]	cos φ _{1/1}	Efficiency class	η [%]	I _{start} [%]	Speed [rpm]	Mounting designation
0.37	71	220-255Δ/ 380-440Y	1.5 - 1.44 / 0.87 - 0.83	0.85 - 0.76	IE3	73.4	550-650	3410-3470	B14/V18 Tapped hole flange
0.55	71	220-255Δ/ 380-440Y	2.15 - 2.05 / 1.25 - 1.2	0.85 - 0.76	IE3	76.8	500-600	3390-3460	
0.75	80	220-255Δ/ 380-440Y	2.95 - 2.75 / 1.7 - 1.6	0.86 - 0.77	IE3	77.0	600-740	3410-3470	
1.1	80	220-255Δ/ 380-440Y	4.15 - 4.0 / 2.4 - 2.3	0.88 - 0.80	IE3	84.0	430-500	3420-3470	
1.5	90	220-277Δ/ 380-480Y	5.35 - 4.7 / 3.1 - 2.7	0.90 - 0.81	IE2 - IE3	84.0 - 85.5	780-1050	3470-3530	
2.2	90	220-277Δ/ 380-480Y	7.7 - 6.35/ 4.45 - 3.7	0.91 - 0.85	IE2 - IE3	85.5 - 86.5	780-1100	3470-3530	
3.0	100	220-277Δ/ 380-480Y	10.8 - 9.35 / 6.2 - 5.4	0.91 - 0.84	IE2 - IE3	87.5 - 88.5	860-1100	3480-3530	
4.0	112	220-277Δ/ 380-480Y	13.6 - 11.8 / 7.8 - 6.8	0.91 - 0.82	IE3	88.5	1000-1470	3510-3540	
5.5	132	220-277Δ/ 380-480Y	18.4 - 16.2 / 10.6 - 9.3	0.90 - 0.80	IE3	89.5	1020-1480	3510-3550	B5/V1 Free-hole flange
7.5	132	220-277Δ/ 380-480Y	24.6 - 20.8 / 14.2 - 12.0	0.90 - 0.82	IE2 - IE3	89.5 - 90.2	680-1050	3490-3530	
11	160	380-480Δ/ 660-690Y	20.8 - 17.2 / 12.0 - 11.6	0.89 - 0.83	IE2 - IE3	90.2 - 91.0	580-890	3520-3550	
15	160	380-480Δ/ 660-690Y	28.0 - 22.4 / 16.2 - 15.6	0.90 - 0.86	IE2 - IE3	90.2 - 91.0	580-890	3520-3550	
18.5	160	380-480Δ/ 660-690Y	34.5 - 28.0 / 20.0 - 16.6	0.89 - 0.84	IE2 - IE3	91.0 - 91.7	670-1100	3520-3560	
22	180	380-480Δ/ 660-690Y	40.0 - 32.5 / 23.0 - 22.2	0.91	IE3	91.7	650-1040	3520-3560	

Siemens



TM03 1710 2805

30*	200	380-420Δ/ 660-725Y	56.0 - 50.0 / 32.0 - 29.0	0.89	IE3	92.4	610-610	3540	B5/V1 Free-hole flange
37*	200	380-420Δ/ 660-725Y	68.0 - 62.0 / 38.5 - 35.0	0.90	IE3	93	630-630	3540	
45*	225	380-420Δ/ 660-725Y	81.0 - 73.0 / 47.0 - 43.0	0.90	IE3	93.6	560-560	3550	
55*	250	380-420Δ/ 660-725Y	99.0 - 90.0 / 57.0 - 52.0	0.90	IE3	93.6	560-560	3570	
75*	280	380-420Δ/ 660-725Y	136 - 122 / 79.0 - 70.0	0.90	IE3	93.8	740-740	3570	
90*	280	380-420Δ/ 660-725Y	161 - 145 / 93.0 - 84.0	0.91	IE3	94.4	780-780	3570	
110*	315	380-420Δ/ 660-725Y	193 - 174 / 112 - 101	0.91	IE3	95.1	780-780	3580	

* Siemens motors operating at 440-480Δ voltage may be loaded with a service factor of 1.15.

7. List of pumped liquids

A number of typical liquids are listed below.

Other pump versions may be applicable, but those stated in the list are considered to be the best choices.

The table is intended as a general guide only and cannot replace actual testing of the pumped liquids and pump materials under specific working conditions.

Therefore, use the list with some caution. Factors such as those mentioned below may affect the chemical resistance of a specific pump version:

- concentration of the pumped liquid
- liquid temperature
- pressure.

Take safety precautions when pumping dangerous liquids.

Notes

D	Often with additives.
	The density and/or viscosity differ from that/those of water.
E	Take this factor into account when calculating motor output and pump performance.
F	Pump selection depends on many factors. Contact Grundfos.
H	Risk of crystallisation/precipitation in shaft seal.
1	Highly flammable liquid.
2	Combustible liquid.
3	Insoluble in water.
4	Low self-ignition point.

Pumped liquid	Chemical formula	Note	Liquid concentration, liquid temperature	CR	CRN
Acetic acid	CH ₃ COOH	-	5 %, 20 °C	-	HQQE
Acetone	CH ₃ COCH ₃	1, F	100 %, 20 °C	-	HQQE
Alkaline degreasing agent		D, F	-	HQQE	-
Ammonium bicarbonate	NH ₄ HCO ₃	E	20 %, 30 °C	-	HQQE
Ammonium hydroxide	NH ₄ OH	-	20 %, 40 °C	HQQE	-
Aviation fuel		1, 3, 4, F	100 %, 20 °C	HQB	-
Benzoic acid	C ₆ H ₅ COOH	H	0.5 %, 20 °C	-	HQQV
Boiler water		-	< 120 °C	HQQE	-
		F	120-180 °C	-	-
Calcareous water		-	< 90 °C	HQQE	-
Calcium acetate (as coolant with inhibitor)	Ca(CH ₃ COO) ₂	D, E	30 %, 50 °C	HQQE	-
Calcium hydroxide	Ca (OH) ₂	E	Saturated solution, 50 °C	HQQE	-
Chloride-containing water		F	< 30 °C, maximum 500 ppm	-	HQQE
Chromic acid	H ₂ CrO ₄	H	1 %, 20 °C	-	HQQV
Citric acid	HOC(CH ₂ CO ₂ H) ₂ COOH	H	5 %, 40 °C	-	HQQE
Completely desalinated water (demineralised water)		-	120 °C	-	HQQE
Condensate		-	120 °C	HQQE	-
Copper sulphate	CuSO ₄	E	10 %, 50 °C	-	HQQE
Corn oil		D, E, 3	100 %, 80 °C	HQQV	-
Diesel oil		2, 3, 4, F	100 %, 20 °C	HQB	-
Domestic hot water (potable water)		-	< 120 °C	HQQE	-
Ethanol (ethyl alcohol)	C ₂ H ₅ OH	1, F	100 %, 20 °C	HQQE	-
Ethylene glycol	HOCH ₂ CH ₂ OH	D, E	50 %, 50 °C	HQQE	-
Formic acid	HCOOH	-	5 %, 20 °C	-	HQQE
Glycerine (glycerol)	OHCH ₂ CH(OH)CH ₂ OH	D, E	50 %, 50 °C	HQQE	-
Hydraulic oil (mineral)		E, 2, 3	100 %, 100 °C	HQQV	-
Hydraulic oil (synthetic)		E, 2, 3	100 %, 100 °C	HQQV	-
Isopropyl alcohol	CH ₃ CHOHCH ₃	1, F	100 %, 20 °C	HQQE	-
Lactic acid	CH ₃ CH(OH)COOH	E, H	10 %, 20 °C	-	HQQV
Linoleic acid	C ₁₇ H ₃₁ COOH	E, 3	100 %, 20 °C	HQQV	-
Methanol (methyl alcohol)	CH ₃ OH	1, F	100 %, 20 °C	HQQE	-
Motor oil		E, 2, 3	100 %, 80 °C	HQQV	-
Naphthalene	C ₁₀ H ₈	E, H	100 %, 80 °C	HQQV	-
Nitric acid	HNO ₃	F	1 %, 20 °C	-	HQQE
Oil-containing water		-	< 100 °C	HQQV	-
Olive oil		D, E, 3	100 %, 80 °C	HQQV	-
Oxalic acid	(COOH) ₂	H	1 %, 20 °C	-	HQQE
Ozone-containing water	(O ₃)	-	< 100 °C	-	HQQE
Peanut oil		D, E, 3	100 %, 80 °C	HQQV	-
Petrol		1, 3, 4, F	100 %, 20 °C	HQB	-
Phosphoric acid	H ₃ PO ₄	E	20 %, 20 °C	-	HQQE
Propanol	C ₃ H ₇ OH	1, F	100 %, 20 °C	HQQE	-
Propylene glycol	CH ₃ CH(OH)CH ₂ OH	D, E	50 %, 90 °C	HQQE	-
Potassium carbonate	K ₂ CO ₃	E	20 %, 50 °C	HQQE	-
Potassium formate (as coolant with inhibitor)	KOOCH	D, E	30 %, 50 °C	HQQE	-
Potassium hydroxide	KOH	E	20 %, 50 °C	-	HQQE
Potassium permanganate	KMnO ₄	-	5 %, 20 °C	-	HQQE
Rape seed oil		D, E, 3	100 %, 80 °C	HQQV	-
Salicylic acid	C ₆ H ₄ (OH)COOH	H	0.1 %, 20 °C	-	HQQE
Silicone oil		E, 3	100 %	HQQV	-
Sodium bicarbonate	NaHCO ₃	E	10 %, 60 °C	-	HQQE
Sodium chloride (as coolant)	NaCl	D, E	30 %, < 5 °C, pH > 8	HQQE	-
Sodium hydroxide	NaOH	E	20 %, 50 °C	-	HQQE
Sodium hypochlorite	NaOCl	F	0.1 %, 20 °C	-	HQQV
Sodium nitrate	NaNO ₃	E	10 %, 60 °C	-	HQQE
Sodium phosphate	Na ₃ PO ₄	E, H	10 %, 60 °C	-	HQQE
Sodium sulphate	Na ₂ SO ₄	E, H	10 %, 60 °C	-	HQQE
Softened water		-	< 120 °C	-	HQQE
Soya oil		D, E, 3	100 %, 80 °C	HQQV	-
Sulphuric acid	H ₂ SO ₄	F	1 %, 20 °C	-	HQQV
Sulphurous acid	H ₂ SO ₃	-	1 %, 20 °C	-	HQQE
Unsalted swimming-pool water		-	Approx. 2 ppm free chlorine (Cl ₂)	HQQE	-

8. Accessories

Pipe connection

Various sets of counterflanges and couplings are available for pipe connection.

Counterflanges for CR

A set consists of one counterflange, one gasket, bolts and nuts.

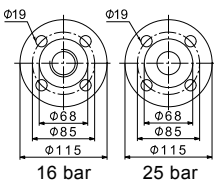
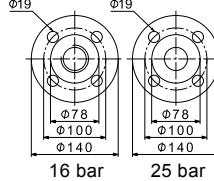
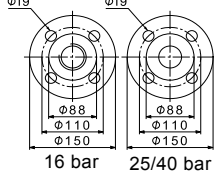
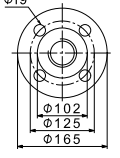
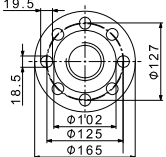
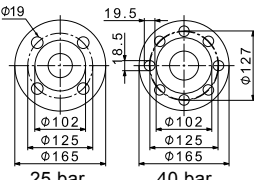
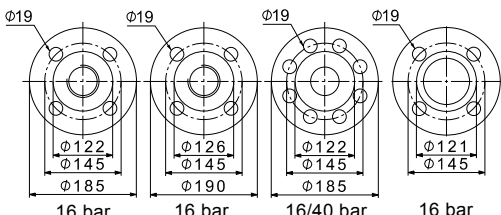
Counterflange	Pump type	Description	Rated pressure	Pipe connection	Product number	
	TM05 0998 2011	CR 1s CR 1 CR 3 CR 5	Threaded	16 bar, EN 1092-2	Rp 1	409901
			For welding	25 bar, EN 1092-2	25 mm, nominal	409902
	TM05 1003 2011	CR 1s CR 1 CR 3 CR 5	Threaded	16 bar, EN 1092-2	Rp 1 1/4	419901
			For welding	25 bar, EN 1092-2	32 mm, nominal	419902
	TM05 1002 2011	CR 10	Threaded	16 bar, EN 1092-2	Rp 1 1/2	429902
			Threaded	16 bar, EN 1092-2	Rp 2	429904
			For welding	25 bar, EN 1092-2	40 mm, nominal	429901
			For welding	40 bar, special flange	50 mm, nominal	429903
	TM05 0999 2011		Threaded	16 bar, EN 1092-2	Rp 2	339903
			Threaded	16 bar, special flange	Rp 2 1/2	339904
	TM05 1005 2011	CR 15 CR 20	Threaded	16 bar, special flange	Rp 2 1/2*	96509578
	TM05 1000 2011		For welding	25 bar, EN 1092-2	50 mm, nominal	339901
			For welding	40 bar, special flange	65 mm, nominal	339902
	TM05 0997 2011	CR 32	Threaded	16 bar, EN 1092-2	Rp 2 1/2	349902
			Threaded	16 bar, special flange	Rp 3	349901
			For welding	16 bar, EN 1092-2	65 mm, nominal	349904
			For welding	40 bar, DIN 2635	65 mm, nominal	349905
			For welding	16 bar, special flange	80 mm, nominal	349903

Counterflange	Pump type	Description	Rated pressure	Pipe connection	Product number
	TM05 0996 2011 CR 45	Threaded	16 bar	Rp 3	350540
		For welding	16 bar	80 mm, nominal	350541
		For welding	40 bar	80 mm, nominal	350542
	TM05 0995 2011 CR 64	Threaded	16 bar, EN 1092-2	Rp 4	369901
		For welding	16 bar, EN 1092-2	100 mm, nominal	369902
		For welding	25 bar, EN 1092-2	100 mm, nominal	369905
	TM06 5157 3915 CR 95	For welding	16 bar, EN 1092-2	100 mm, nominal	369902
		For welding	25/40 bar, EN 1092-2	100 mm, nominal	-
	TM03 8891 2707 TM06 5171 4015 CR 125 CR 155	For welding	16 bar, EN 1092-2	150 mm, nominal	-
		For welding	25/40 bar, EN 1092-2	150 mm, nominal	-

* Flange with 20 mm higher collar. With this collar, the installation dimensions of a CR 20 will be identical to those of a CR 32. If a CR 32 is replaced by a CR 20, the base must be raised by 15 mm.

Counterflanges for CRN

Counterflanges for CRN pumps are made of stainless steel EN 1.4401 (≈ AISI 316).

A set consists of one counterflange, one gasket, bolts and nuts.

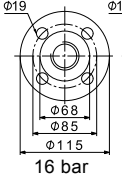
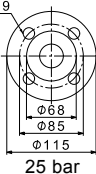
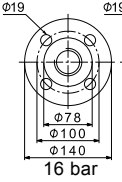
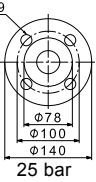
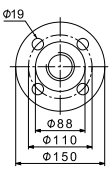
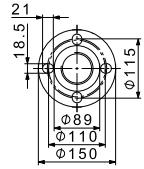
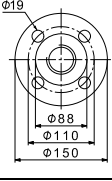
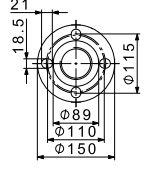
Counterflange	Pump type	Description	Rated pressure	Pipe connection	Product number
 16 bar	TM05 0998 2011 CRN 1s, 1, 3, 5	Threaded	16 bar, EN 1092-1	Rp 1	405284
 25 bar		For welding	25 bar, EN 1092-1	25 mm, nominal	405285
 16 bar	TM05 1003 2011 CRN 1s, 1, 3, 5	Threaded	16 bar, EN 1092-1	Rp 1 1/4	415304
 25 bar		For welding	25 bar, EN 1092-1	32 mm, nominal	415305
 16 bar	TM05 1001 2011	Threaded	16 bar, EN 1092-1	Rp 1 1/2	425245
 16 bar	TM05 1006 2011	Threaded	16 bar, EN 1092-1	Rp 2	96509570
 25 bar	TM05 1001 2011	For welding	25 bar, EN 1092-1	40 mm, nominal	425246
 25 bar	TM05 1006 2011	For welding	25 bar, special flange	50 mm, nominal	96509571

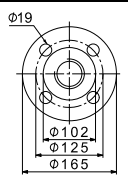
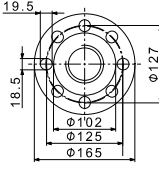
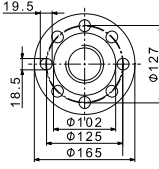
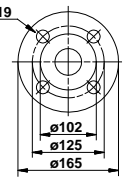
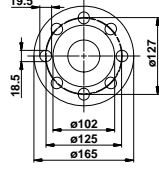
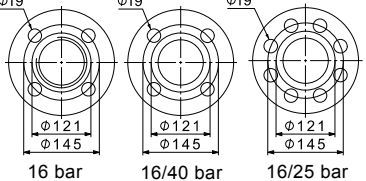
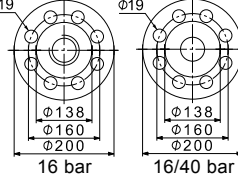
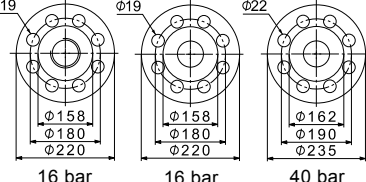
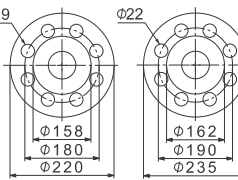
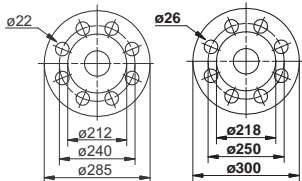
Counterflange	Pump type	Description	Rated pressure	Pipe connection	Product number
	TM05 0999 2011	Threaded	16 bar, EN 1092-1	Rp 2	335254
		Threaded	16 bar, special flange	Rp 2 1/2	96509575
	TM05 1005 2011	Threaded	16 bar, special flange	Rp 2 1/2*	96509579
	TM03 0402 2011	For welding	25 bar, EN 1092-1	50 mm, nominal	335255
		For welding	25 bar, special flange	65 mm, nominal	96509573
	TM05 0994 2011	Threaded	16 bar	Rp 2 1/2	349910
		Threaded	16 bar, special flange	Rp 3	349911
		For welding	16 bar	65 mm, nominal	349906
		For welding	40 bar	65 mm, nominal	349908
	TM05 0996 2011	Threaded	16 bar	Rp 3	350543
		For welding	16 bar	80 mm, nominal	350544
		For welding	40 bar	80 mm, nominal	350545
	TM05 0995 2011	Threaded	16 bar	Rp 4	369904
		For welding	16 bar	100 mm, nominal	369903
		For welding	40 bar	100 mm, nominal	369906
	TM06 5157 3915	For welding	16 bar, EN 1092-1	100 mm, nominal	360003
		For welding	25/40 bar, EN 1092-1	100 mm, nominal	369906
	TM03 8891 2707 TM06 5171 4015	For welding	16 bar, EN 1092-1	150 mm, nominal	98052936
		For welding	25/40 bar, EN 1092-1	150 mm, nominal	96750478

* Flange with 20 mm higher collar. With this collar, the installation dimensions of a CR 20 will be identical to those of a CR 32.
If a CR 32 is replaced by a CR 20, the base must be raised by 15 mm.

PJE couplings for CRN

Materials in contact with the pumped liquid are made of stainless steel EN 1.4401 (≈ AISI 316) and rubber.

A set consists of two coupling halves (Victaulic type 77), one gasket, one pipe stub (for welding or threaded), bolts and nuts.

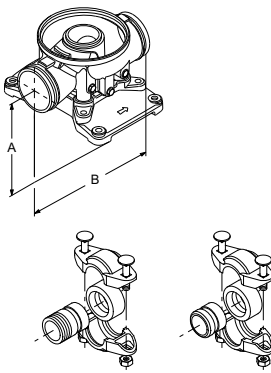
Coupling	Pump type	Pipe stub	Maximum pressure [bar]	A	B	Pipe connection	Rubber parts	Number of coupling sets required	Product number	
	CRN 1s, 1, 3, 5	Threaded	69	50	320	R 1 1/4	EPDM	2	419911	
							FKM	2	419905	
		For welding	69	50	280	DN 32	EPDM	2	419912	
							FKM	2	419904	
		CRN 10, 15, 20	Threaded	69	80	377	R 2	EPDM	2	339911
								FKM	2	339918
	CRN 32	For welding	69	105	420	DN 80	EPDM	2	98144746	
							FKM	2	98144749	
	CRN 45, 64	For welding	69	140	465	DN 100	EPDM	2	98144752	
							FKM	2	98144755	
CRN 95	For welding	69	140	465	DN 100	EPDM	2	98144752		
						FKM	2	98144755		
CRN 125 CRN 155	For welding	69	-	-	DN 150	EPDM	2	-		
						FKM	2	-		

TM06 9172 1817 - TM00 3808 1094

FlexiClamp base connections

All sets comprise the necessary number of bolts and nuts as well as a gasket or O-ring.

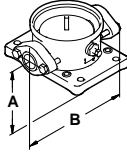
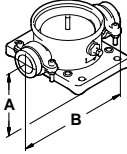
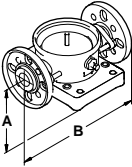
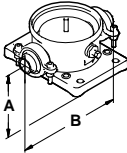
Base connection	Pump type	Connection	Pipe connection	PN	A	B	Rubber parts	Number of coupling sets required	Product number
	TM02 7368 3303 CRI CRN 1s, 1, 3, 5	Oval (cast iron)	Rp 1	16	50	210	Klingersil	1	96449748
			Rp 1 1/4					1	96449749
		Oval (stainless steel)	Rp 1					2	96449746
			Rp 1 1/4					2	96449747
	TM02 7369 3303 CRI CRN 1s, 1, 3, 5	Union	G 2	25	50	228	EPDM	2	96449743
							FKM	2	96449744
	TM02 7370 3303 CRI CRN 1s, 1, 3, 5	DIN (stainless steel)	DN 25	16	75	250	EPDM	2	96449745
			DN 32				FKM	2	96449900
	TM02 7371 3303 CRI CRN 1s, 1, 3, 5	Clamp, threaded pipe stub	Rp 1	25	50	208	EPDM	2	405280
			FKM				2	405281	
			Rp 1 1/4				EPDM	2	415296
			1" NPT				FKM	2	415297
			1 1/4" NPT				EPDM	2	405291
							FKM	2	405292
							EPDM	2	415311
							FKM	2	415312
			Clamp, pipe stub for welding				EPDM	2	405282
							FKM	2	405283
	EPDM	2	415300						
	FKM	2	415301						

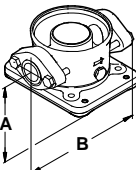
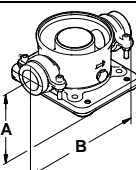
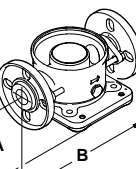
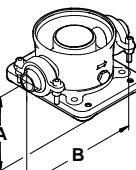
Base connection	Pump type	Connection	Pipe connection	PN	A	B	Rubber parts	Number of coupling sets required	Product number	
	CRI 10 CRN 10 TM02 7372 3303	Oval (cast iron)	Rp 1 1/4	16	80	260	Klingersil	2	96498775	
			Rp 1 1/2					2	96498727	
			Rp 2					2	96498836	
			Oval (stainless steel)					Rp 1 1/4	2	96498776
			Rp 1 1/2					2	96498728	
			Rp 2					2	96498835	
	CRI 10 CRN 10 TM02 7374 3303	Union	G 2 3/4	25	80	288	EPDM	2	96500275	
							FKM	2	96500276	
	CRI 10 CRN 10 TM02 7373 3303	FGJ (cast iron)	DN 40	16	80	316	EPDM	2	96498840	
							FKM	2	96500119	
		FGJ (stainless steel)	DN 40				EPDM	2	96500263	
							FKM	2	96500264	
		FGJ (cast iron)	DN 50				EPDM	2	96500265	
							FKM	2	96500266	
FGJ (stainless steel)	DN 50	EPDM	2	96500267						
		FKM	2	96500269						
	CRI 10 CRN 10 TM02 7375 3303	Clamp, threaded pipe stub	Rp 1 1/2	25	80	346	EPDM	2	425238	
			FKM				2	425239		
			Rp 2				259	EPDM	2	335241
							FKM	2	335242	
			Rp 2 1/2				EPDM	2	96508600	
							FKM	2	96508601	
			Clamp, pipe stub for welding				48.3 (DN 40)	EPDM	2	425242
							FKM	2	425243	
60.3 (DN 50)	EPDM	2	335251							
	FKM	2	335252							

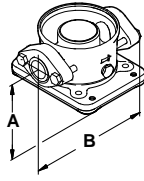
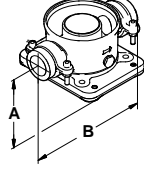
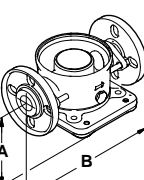
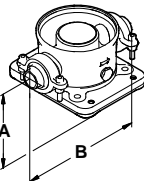
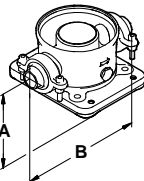
Base connection	Pump type	Connection	Pipe connection	PN	A	B	Rubber parts	Number of coupling sets required	Product number	
	CRI 15, 20 CRN 15, 20	Oval (cast iron)	Rp 1 1/4	10	90	260	Klingsil	2	96498775	
			Rp 1 1/2					2	96498727	
			Rp 2					2	96498836	
			Rp 1 1/4					2	96498776	
			Oval (stainless steel)					Rp 1 1/2	2	96498728
			Rp 2					2	96498835	
	CRI 15, 20 CRN 15, 20	Union	G 2 3/4	25	90	288	EPDM	2	96500275	
							FKM	2	96500276	
	CRI 15, 20 CRN 15, 20	FGJ (cast iron)	DN 40	10	90	334	EPDM	2	96498840	
							FKM	2	96500119	
							FGJ (stainless steel)	EPDM	2	96500263
							FKM	2	96500264	
							FGJ (cast iron)	EPDM	2	96500265
							FKM	2	96500266	
	CRI 15, 20 CRN 15, 20	Clamp, threaded pipe stub	Rp 1 1/2	25	90	346	EPDM	2	425238	
			FKM				2	425239		
			Rp 2				EPDM	2	335241	
			FKM				2	335242		
			Rp 2 1/2				EPDM	2	96508600	
			FKM				2	96508601		
	CRI 15, 20 CRN 15, 20	Clamp, pipe stub for welding	48.3 (DN 40)	-	-	-	EPDM	2	425242	
			FKM				2	425243		
			60.3 (DN 50)				EPDM	2	335251	
			FKM				2	335252		

LiqTec

The LiqTec dry-running protection unit protects the pump and process against dry running and temperatures exceeding 130 ± 5 °C. Connected to the motor PTC sensor, LiqTec also monitors the motor temperature.

LiqTec is prepared for DIN rail mounting in control cabinet.

Enclosure class: IPX0.

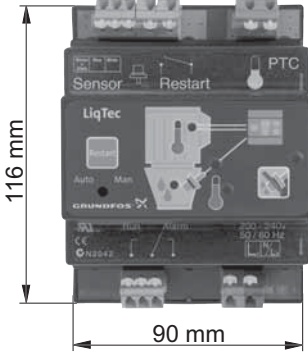
LiqTec unit	Pump type	Voltage [V]	LiqTec	Sensor 1/2"	Cable 5 m	Extension cable 15 m	Product number
	CR CRI CRN	200-240	•	•	•	-	96556429
		80-130	•	•	•	-	96556430
		-	-	-	-	•	96443676

TM03 2108 3705

Sensors

Sensor	Type	Supplier	Measuring range	Product number
Flowmeter	SITRANS FM MAGFLO MAG 5100 W	Siemens	1-5 m ³ (DN 25)	ID8285
	SITRANS FM MAGFLO MAG 5100 W		3-10 m ³ (DN 40)	ID8286
	SITRANS FM MAGFLO MAG 5100 W		6-30 m ³ (DN 65)	ID8287
	SITRANS FM MAGFLO MAG 5100 W		20-75 m ³ (DN 100)	ID8288
Temperature sensor	TTA (0) 25	Carlo Gavazzi	0-25 °C	96432591
	TTA (-25) 25		-25 - +25 °C	96430194
	TTA (50) 100		50-100 °C	96432592
	TTA (0) 150		0-150 °C	96430195
Accessory for temperature sensor. All with 1/2 RG connection	Protecting tube Ø9 x 50 mm	Carlo Gavazzi		96430201
	Protecting tube Ø9 x 100 mm			96430202
	Cutting ring bush			96430203
Temperature sensor, ambient temperature	WR 52	tmg (DK: Plesner)	-50 - +50 °C	ID8295
Differential-temperature sensor	ETSD	Honsberg	0-20 °C	96409362
	ETSD		0-50 °C	96409363

Note: All sensors have 4-20 mA signal output.

Danfoss pressure sensor kits

Content	Liquid temperature	Pressure [bar]	Product number
<ul style="list-style-type: none"> Danfoss pressure transmitter, type MBS 3000, with 2 m screened cable. Connection: G 1/2 A (DIN 16288 - B6kt) 5 cable clips (black) Instructions PT (400212) 	-40 - +85 °C	0-4	96428014
		0-6	96428015
		0-10	96428016
		0-16	96428017
		0-25	96428018

DPI differential-pressure sensor kit

Content	Pressure [bar]	Product number
<ul style="list-style-type: none"> 1 sensor incl. 0.9 m screened cable (7/16" connections) 1 original DPI bracket for wall mounting 1 Grundfos bracket for mounting on motor 2 M4 screws for mounting of sensor on bracket 1 M6 screw (self-cutting) for mounting on MGE 90/100 1 M8 screw (self-cutting) for mounting on MGE 112/132 3 capillary tubes (short/long) 2 fittings (1/4" - 7/16") 5 cable clips (black) Installation and operating instructions (00480675) Service kit instructions. 	0 - 0.6	96611522
	0 - 1.0	96611523
	0 - 1.6	96611524
	0 - 2.5	96611525
	0 - 4.0	96611526
	0 - 6.0	96611527
	0-10	96611550

Adapter kit for sensor¹⁾

Content	Type	Product number
Adapter for sensor	G 1/2 EPDM	99352712
	G 1/2 FKM	99352737

¹⁾ Applies to CRN 95.

9. Variants

The variants are available on request.

Although the Grundfos CR, CRI, CRN product range offers a number of pumps for different applications, customers require specific pump solutions to satisfy their needs. See the following documents:

- Grundfos CR "Custom-built pumps" data booklet
- Grundfos "CR, CRN high pressure" data booklet.

Below please find the range of options available for customising the CR pumps to meet the customers' demands.

Contact Grundfos for further information or for requests other than the ones mentioned below.

Motors

Variant	Description
ATEX-approved motor	For operation in hazardous atmospheres, explosion-proof or dust-ignition-proof motors may be required.
Motor with anti-condensation heating unit	For operation in humid environments motors with built-in anti-condensation heating unit may be required.
Motor with thermal protection	We offer motors with built-in bimetallic thermal switches or temperature-controlled PTC sensors (thermistors) incorporated in the motor windings.
Oversize motor	Ambient temperatures above 40 °C or installation at altitudes of more than 1000 metres above sea level require the use of an oversize motor (i.e. derating).
4-pole motor	We offer 4-pole standard motors.

Shaft seals

Variant	Description
Shaft seal with FFKM O-ring	Shaft seals with FFKM or FXM O-ring are recommended for applications where the pumped liquid may damage the standard O-ring material.
Seal with flush, quench seal	Recommended for applications involving crystallising, hardening or sticky liquids.
Air-cooled shaft seal system	Recommended for applications involving extremely high temperatures. No conventional mechanical shaft seal can withstand liquid temperatures of up to 180 °C for any length of time. For such applications, Grundfos' unique air-cooled shaft seal system is recommended. In order to ensure a low liquid temperature around the standard shaft seal, the pump is fitted with a special air-cooled shaft seal chamber. No separate cooling is required.
Double seal with pressure chamber	Recommended for applications involving poisonous or explosive liquids. Protects the surrounding environment and the people working in the vicinity of the pump. Consists of two seals mounted in a "back-to-back" arrangement inside a separate pressure seal chamber. As the pressure in the chamber is higher than the pump pressure, leakage is prevented. A dosing pump or a special pressure intensifier generates the seal chamber pressure.
CR MAGdrive	Magnetically driven pumps for industrial applications. Key applications are industrial processes involving the handling of aggressive, environmental, dangerous or volatile liquids, e.g. organic compounds, solvents, etc.

Pumps

Variant	Description
Horizontally mounted pump	For safety or height reasons, certain applications, for instance on ships, require the pump to be mounted in the horizontal position. For easy installation the pump is fitted with brackets that support motor and pump.
Low-temperature pump	Exposed to temperatures down to -40 °C, coolant pumps may require neck rings with a different diameter in order to prevent impeller drag.
High-pressure pump up to 47 bar	For high-pressure applications, we offer a unique double pump system capable of generating a pressure of up to 47 bar.
Low-NPSH pump (improved suction)	Recommended for boiler-feed applications where cavitation may occur due to poor inlet conditions.
Pump with bearing flange	The bearing flange is suitable for applications where the inlet pressure is higher than the maximum pressure recommended. The bearing flange increases the life of motor bearings. Recommended for standard motors.
Belt-driven pump	Belt-driven pumps designed to operate in places with limited space or where no electrical power is available.
Pump for pharmaceutical and biotechnological applications	CRN pumps designed for applications requiring the sterilisation and CIP capability of pipes, valves and pumps. (CIP = Cleaning-In-Place.)

Connections and other variants

Variant	Description
Pipe connections	In addition to the wide range of standard flange connections, a 16 bar DIN standard clamping flange is available. Customized flanges are available according to specifications.
TriClamp connection	TriClamp connections are of a hygienic design with a sanitary coupling for use in the pharmaceutical and food industry.
Electropolished pump	To substantially reduce the risk of corrosion of the materials. For use in the pharmaceutical and food industry.

10. Grundfos Product Center

Online search and sizing tool to help you make the right choice.

<http://product-selection.grundfos.com>



"SIZING" enables you to size a pump based on entered data and selection choices.

"REPLACEMENT" enables you to find a replacement product. Search results will include information on the following:

- the lowest purchase price
- the lowest energy consumption
- the lowest total life cycle cost.

The screenshot shows the Grundfos Product Center website. At the top, there is a navigation bar with the Grundfos logo and 'PRODUCT CENTER'. Below this is a search bar with a 'SEARCH' button. The main content area features four large buttons: 'SIZING' (with a subtext 'Enter pump sizing'), 'CATALOGUE' (with a subtext 'Products and services'), 'REPLACEMENT' (with a subtext 'Replace an old pump with a new'), and 'LIQUIDS' (with a subtext 'Find pump by liquid'). Below these buttons is a 'QUICK SIZING' section with input fields for 'Flow (Q)*' and 'Head (H)*', and radio buttons for 'Select what to size by: Size by application', 'Size by pump design', and 'Size by pump family'. A 'START SIZING' button is also present. At the bottom of the screenshot, there are callout boxes with text explaining the 'SIZING', 'REPLACEMENT', 'CATALOGUE', and 'LIQUIDS' features.

www.grundfos.com Login

GRUNDFOS | PRODUCT CENTER Product range: United Kingdom | 50 Hz | Language: English
Change settings

HOME FIND PRODUCT COMPARE YOUR PROJECTS SAVED ITEMS HELP 1.4.23

FIND PRODUCTS AND SOLUTIONS

Input product number or a whole or partial product name

SIZING
Enter pump sizing

CATALOGUE
Products and services

REPLACEMENT
Replace an old pump with a new

LIQUIDS
Find pump by liquid

QUICK SIZING

Enter duty point:

Flow (Q)* m³/h

Head (H)* m

Select what to size by:

Size by application

Size by pump design

Size by pump family

START SIZING

ADVANCED SIZING: Advanced sizing by application Guided selection

"SIZING" enables you to size a pump based on entered data and selection choices.

"REPLACEMENT" enables you to find a replacement product. Search results will include information on the following:

- the lowest purchase price
- the lowest energy consumption
- the lowest total life cycle cost.

"CATALOGUE" gives you access to the Grundfos product catalogue.

"LIQUIDS" enables you to find pumps designed for aggressive, flammable or other special liquids.

All the information you need in one place

Performance curves, technical specifications, pictures, dimensional drawings, motor curves, wiring diagrams, spare parts, service kits, 3D drawings, documents, system parts. The Product Center displays any recent and saved items - including complete projects - right on the main page.

Downloads

On the product pages, you can download installation and operating instructions, data booklets, service instructions, etc. in PDF format.

Subject to alterations.

99301180 0418

ECM: 1231740

GRUNDFOS A/S
DK-8850 Bjerringbro . Denmark
Telephone: +45 87 50 14 00
www.grundfos.com

GRUNDFOS 